

MICHAEL S. CAZZARI
Town Supervisor

ROBERT F. SCHANIL, JR.
Town Councilman
Deputy Supervisor

STEPHEN J. BARANOWSKI
Town Councilman
FRANK D. LOMBARDI
Town Councilman
SUZANNE MC DONOUGH
Town Councilwoman

TOWN OF CARMEL
TOWN HALL



60 McAlpin Avenue
Mahopac, New York 10541
Tel. (845) 628-1500 • Fax (845) 628-6836
www.ci.carmel.ny.us

ANN SPOFFORD
Town Clerk

KATHLEEN KRAUS
Receiver of Taxes

MICHAEL SIMONE
Superintendent of Highways
Tel. (845) 628-7474

TOWN BOARD VOTING MEETING/WORK SESSION
Wednesday, June 15, 2022 6:30pm

6:30pm Special Executive Session Meeting:

1. Update on Negotiations Mud Pond Sewer Plant

• **Roll Call - Attendance**

PLEDGE OF ALLEGIANCE - MOMENT OF SILENCE

Town Board Voting Meeting:

- **Public Comment Three (3) Minutes Agenda Items Only**
- **Accept Town Board Minutes – May 18, June 1, 2022**

1. Res: Authorizing Mailing of Lake Mahopac Park District Newsletter
2. Res: Authorizing Budget Modifications
3. Res: Accepting Proposal for Purchase and Installation of Comminutor – Carmel Sewer District #2
4. Res: Acknowledging Emergency Repairs/Services Carmel Water and Sewer Districts
5. Res: Authorizing Entry into Agreement for Copier Lease – Town of Carmel Highway Department
6. Res: Accepting Proposal for Purchase and Installation of Guiderails – Town of Carmel Highway Department
7. Res: Setting Rates for 2022 Seasonal Employees Lake Secor Park District
8. Res: Authorizing Additions/Deletions to the Active List of the Mahopac Volunteer Fire Department

9. Res: Order Calling Public Hearing in the Matter of the Increase and Improvement of the Facilities of Consolidated Sewer District #5, in the Town of Carmel, Putnam County, New York (July 6, 2022)
10. Res: Accepting Donation of Vacation Time by Town of Carmel Employee
11. Res: Setting Public Hearing of Public Hearing on a Proposed Local Law Proposing Multiple Amendments to Chapter 156 of the Town of Carmel entitled "Zoning" (July 13, 2022)
 - **Motion to Adjourn Voting Meeting**
 - **Motion to Open Town Board Work Session**

Town Board Work Session:

- **Public Comment Three (3) Minutes Agenda Items Only**
 1. James Gilchrist, Director of Recreation & Parks – Consider Request to Authorize Eagle Scout Project – Max Head, Eagle Scout Candidate, Boy Scout Troop 1, Mahopac, Build and Install Five Informational Signs – Sycamore Park
 2. Richard Franzetti, PE, Town Engineer – Consider Request to Authorize Awarding of Bids for the Purchase of Chemicals for the Treatment of the Various Town Water and Sewer Plants
- **Town Board Comments**
- **Motion to Move into Executive Session**

Executive Session:

1. Police Chief Anthony Hoffman – Personnel
 2. Personnel
- **Motion to Adjourn Meeting**

RESOLUTION #1
RESOLUTION AUTHORIZING MAILING OF LAKE MAHOPAC PARK
DISTRICT NEWSLETTER

RESOLVED that the Town Board of the Town of Carmel, acting as the Commissioners of the Lake Mahopac Park District, hereby authorizes the mailing of the 2022 newsletter as prepared by the Lake Mahopac Park District Advisory Board to all properties within the district and further directs that the cost thereof be charged as a district expense.

Resolution

Offered by: _____

Seconded by: _____

<u>Roll Call Vote</u>	<u>YES</u>	NO
Stephen Baranowski	_____	_____
Frank Lombardi	_____	_____
Suzanne McDonough	_____	_____
Robert Schanil	_____	_____
Michael Cazzari	_____	_____

RESOLUTION #2

RESOLUTION AUTHORIZING BUDGET MODIFICATIONS

WHEREAS the Town Comptroller MaryAnn Maxwell has reviewed the proposed Budget Modifications for the period ending May 2022 with the Town Board which are detailed and explained on the attached Budget Revisions Schedule 2022/02

NOW, THEREFORE, BE IT RESOLVED that the Town Board of the Town of Carmel hereby authorizes and ratifies the Budget Modifications/Revisions for the period ending May 31, 2022 as shown itemized on schedule 2022/02 which is attached hereto, incorporated herein and made a part hereof.

Resolution

Offered by: _____

Seconded by: _____

<u>Roll Call Vote</u>	<u>YES</u>	<u>NO</u>
Stephen Baranowski	_____	_____
Frank Lombardi	_____	_____
Suzanne McDonough	_____	_____
Robert Schanil	_____	_____
Michael Cazzari	_____	_____

TOWN OF CARMEL
BUDGET REVISIONS APRIL-MAY 2022 #2022/02

BUDGET REVISION NUMBER	ACCOUNT	ACCOUNT TITLE & TRANSFER DESCRIPTION	INCREASE USES & SOURCES OF FUNDS	DECREASE USES & SOURCES OF FUNDS
GENERAL FUND				
1	100.3120.0024	POLICE ACCIDENT REPAIRS	2,000.00	
	100.1989.9909	APPROPRIATED FUND BALANCE	*	2,000.00
		- PROVIDE FOR POLICE VEHICLE ACCIDENT REPAIRS FROM PRIOR YEAR INSURANCE CLAIM		
2	100.1930.0040	CERTIORARI SETTLEMENTS	40,000.00	
	100.1989.9876	RESERVE FOR CERTIORARI SETTLEMENTS	*	40,000.00
		- PROVIDE FOR CERTIORARI SETTLEMENTS		
3	100.1220.0012	SUPERVISOR STAFF OVERTIME	300.00	
	100.1220.0013	SUPERVISOR TEMPORARY STAFF		300.00
		- TRANSFER FOR SUPERVISOR STAFF OVERTIME		
4	100.1610.0045	CENTRAL SERVICE ADMIN CONTRACT	125.00	
	100.1610.0013	CENTRAL SERVICE TEMPORARY STAFF		125.00
		- TRANSFER FOR EMPLOYEE ASSISTANCE PROGRAM		
5	100.1989.0040	UNCLASSIFIED EXPENSE	5,000.00	
	100.1990.0040	CONTINGENT ACCOUNT		5,000.00
		- TRANSFER FOR POSTAGE EXPENSE FOR MAILING COVID TEST KITS		
6	100.3120.0027	POLICE OTHER EQUIPMENT	1,600.00	
	100.1990.0040	CONTINGENT ACCOUNT		1,600.00
		- TRANSFER FOR PURCHASE OF LICENSE PLATE & SECURITY CAMERAS		
7	100.7020.0020	RECREATION ADMIN OFFICE EQUIPMENT	3,000.00	
	100.7110.0012	PARK STAFF OVERTIME	500.00	
	100.7115.0040	AIRPORT PARK CONTRACTUAL EXPENSES	5,000.00	
	100.7110.0013	PARK MAINTENANCE TEMPORARY STAFF		500.00
	100.7112.0045	MCDONOUGH FIELDS PARK IMPROVEMENTS		5,000.00
	100.7180.0022	MAHOPAC LAKEFRONT		3,000.00
		- TRANSFER FOR MISCELLANEOUS RECREATION EXPENSES		
HIGHWAY FUND				
8	500.5148.0040	SERVICE FOR OTHER GOVTS	3,347.00	
	500.5010.2681	INSURANCE RECOVERY - ASSETS	*	3,347.00
		- PROVIDE FOR VEHICLE REPAIRS FROM INSURANCE CLAIM		
8A	500.5110.0012	GENERAL REPAIR LABOR OVERTIME	3,500.00	
	500.5110.0083	WORKERS COMPENSATION		3,500.00
		- TRANSFER FOR GENERAL REPAIR OVERTIME		
CARMEL FIRE PROTECTION DIST #2				
9	302.3410.0045	DRY HYDRANT EXPENDITURES	4,500.00	
	302.3410.0099	WORKERS COMP INSURANCE		4,500.00
		- TRANSFER FOR DRY HYDRANT SURVEY		
CARMEL WATER DISTRICT #1				
10	601.8310.0020	EQUIPMENT	2,000.00	
	601.8310.0040	CONTRACTUAL EXPENSES	10,000.00	
	601.8310.0047	EMERGENCY REPAIRS	17,750.00	
	601.8310.0099	REPAIR RESERVE FUND		4,750.00
	601.8310.9909	APPROPRIATED FUND BALANCE	*	25,000.00
		- PROVIDE AND TRANSFER FOR EQUIPMENT AND EMERGENCY REPAIRS		

TOWN OF CARMEL
BUDGET REVISIONS APRIL-MAY 2022 #2022/02

BUDGET REVISION NUMBER	ACCOUNT	ACCOUNT TITLE & TRANSFER DESCRIPTION	INCREASE USES & SOURCES OF FUNDS	DECREASE USES & SOURCES OF FUNDS
CARMEL WATER DISTRICT #3				
11	603.8310.0020	EQUIPMENT	10,890.00	
	603.8310.0099	REPAIR RESERVE FUND		10,890.00
		- TRANSFER FOR EMERGENCY PUMP REPLACEMENT		
CARMEL WATER DISTRICT #6				
12	606.8310.0047	EMERGENCY REPAIRS	5,000.00	
	606.8310.0099	REPAIR RESERVE FUND		5,000.00
		- TRANSFER FOR EMERGENCY REPAIRS		
CARMEL WATER DISTRICT #7				
13	607.8310.0047	EMERGENCY REPAIRS	5,000.00	
	607.8310.0099	REPAIR RESERVE FUND		5,000.00
		- TRANSFER FOR EMERGENCY REPAIRS		
CARMEL WATER DISTRICT #8				
14	608.8310.0047	EMERGENCY REPAIRS	10,500.00	
	608.8310.0090	CONTINGENCY		10,500.00
		- TRANSFER FOR EMERGENCY REPAIRS		
CARMEL WATER DISTRICT #10				
15	610.8310.0040	CONTRACTUAL EXPENSES	6,000.00	
	610.8310.0047	EMERGENCY REPAIRS	8,600.00	
	610.8310.0020	EQUIPMENT		6,000.00
	610.8310.0090	CONTINGENCY		8,600.00
		- TRANSFER FOR CONTRACTUAL AND EMERGENCY REPAIRS		
CARMEL WATER DISTRICT #13				
16	613.8310.0020	EQUIPMENT	2,000.00	
	613.8310.0047	EMERGENCY REPAIRS	2,500.00	
	613.8310.0099	REPAIR RESERVE FUND		4,500.00
		- TRANSFER FOR PURCHASE OF TURBINE PUMP AND EMERGENCY REPAIRS		
CARMEL SEWER DISTRICT #7				
17	707.8130.0140	MICRO - CONTRACTUAL EXPENSES	15,000.00	
	707.8130.0040	CONTRACTUAL EXPENSES		5,000.00
	707.8130.0049	SERVICE - OTHER DEPTS/GOVTS		3,500.00
	707.8130.0090	CONTINGENCY		6,500.00
		- TRANSFER FOR MICROFILTRATION CONTRACTUAL EXPENSES		
DRAINAGE CAPITAL PROJECT				
18	900.1989.0012	PROJECT OVERTIME EXPENSE	15,000.00	
	900.1989.0040	CONTRACTUAL EXPENDITURES	175,000.00	
	900.1989.0048	OTHER PROJECT EXPENDITURES	8,500.00	
	900.1989.0080	FICA/MED EXPENSE	1,500.00	
	900.1989.5710	PROCEEDS OF BORROWING	*	200,000.00
		- RECORD 2022 CAPITAL AUTHORIZATION		
HIGHWAY RESURFACING CAPITAL PROJECT				
19	950.5112.0012	PROJECT OVERTIME	9,000.00	
	950.5112.0045	CONTRACTED PAVING SERVICES	725,000.00	
	950.5112.0048	OTHER PROJECT EXPENDITURES	15,000.00	
	950.5112.0082	FICA/MED EXPENSE	1,000.00	
	950.5112.5710	PROCEEDS OF BORROWING	*	750,000.00
		- RECORD 2022 CAPITAL AUTHORIZATION		

TOWN OF CARMEL
BUDGET REVISIONS APRIL-MAY 2022 #2022/02

BUDGET REVISION NUMBER	ACCOUNT	ACCOUNT TITLE & TRANSFER DESCRIPTION	INCREASE USES & SOURCES OF FUNDS	DECREASE USES & SOURCES OF FUNDS
SPECIAL DRAINAGE CAPITAL PROJECT				
20	902.1989.0040	CONTRACTUAL EXPENDITURES	216,000.00	
	902.1989.4300	FEDERAL AID - ARPA	*	216,000.00
		- PROVIDE FOR ENGINEERING SERVICES FOR BIRCH ROAD DRAINAGE PROJECT FROM COUNTY ARPA FUNDS		
LAKE MAHOPAC PARK CAPITAL FUND				
21	942.7140.0044	ENGINEERING SERVICES	70,000.00	
	942.7140.0040	CONTRACTUAL EXPENSES	2,500.00	
	942.7140.0048	OTHER EXPENDITURES	2,500.00	
	942.7140.5710	PROCEEDS OF BORROWING	*	75,000.00
		- PROVIDE FOR CAPITAL PROJECT COSTS FROM APPROVED BORROWING		
CARMEL WATER DISTRICT #2 CAPITAL FUND				
22	962.8310.0045	CONTRACT IMPROVEMENTS	3,248,400.00	
	962.8310.5710	PROCEEDS OF BORROWING	*	3,248,400.00
		- PROVIDE FOR CAPITAL PROJECT COSTS FROM APPROVED BORROWING (WATER MAIN LINING PHASE 2)		
MISCELLANEOUS CAPITAL FUNDS				
23	960.8310.0040	WD#10 CAPITAL FUND - CONTRACTUAL EXPENSES	78,585.00	
	961.8310.0040	WD#1 CAPITAL FUND - CONTRACTUAL EXPENSES	37,076.00	
	962.8310.0040	WD#2 CAPITAL FUND - CONTRACTUAL EXPENSES	1,123,000.00	
	963.8310.0040	WD#3 CAPITAL FUND - CONTRACTUAL EXPENSES	332,400.00	
	968.8310.0040	WD#8 CAPITAL FUND - CONTRACTUAL EXPENSES	520,755.00	
	983.8310.0040	WD#13 CAPITAL FUND - CONTRACTUAL EXPENSES	51,584.00	
	984.8310.0040	WD#14 CAPITAL FUND - CONTRACTUAL EXPENSES	481,450.00	
	960.8310.5710	PROCEEDS OF BORROWING	*	78,585.00
	961.8310.5710	PROCEEDS OF BORROWING	*	37,076.00
	962.8310.5710	PROCEEDS OF BORROWING	*	1,123,000.00
	963.8310.5710	PROCEEDS OF BORROWING	*	332,400.00
	968.8310.5710	PROCEEDS OF BORROWING	*	520,755.00
	983.8310.5710	PROCEEDS OF BORROWING	*	51,584.00
	984.8310.5710	PROCEEDS OF BORROWING	*	481,450.00
		- PROVIDE FOR CAPITAL PROJECT COSTS FROM APPROVED BORROWING (STORAGE TANK REHAB)		

RESOLUTION #3

**RESOLUTION ACCEPTING PROPOSAL FOR PURCHASE AND INSTALLATION OF
COMMINUTOR – CARMEL SEWER DISTRICT #2**

RESOLVED that the Town Board of the Town of Carmel, acting as Commissioners of Carmel Sewer District #2, and upon the recommendation of Town of Carmel Town Engineer Richard J. Franzetti, P.E. as fully detailed his memo dated, May 5, 2022, hereby accepts the proposal of JWC Environmental, Santa Ana, California, for the purchase of a Comminutor at the Carmel Sewer District #2 Treatment Plant at a cost not to exceed \$25,871.50, in accordance with the proposal/invoice dated May 20, 2022; and

BE IT FURTHER RESOLVED that the Town Board of the Town of Carmel accepts the proposal of Inframark, Newburgh, NY for the installation of the Comminutor at Carmel Sewer District #2 at a cost not to exceed \$2,720.00, in accordance with the proposal dated May 25, 2022; and

BE IT FURTHER RESOLVED that Town Supervisor Michael Cazzari is hereby authorized to sign all necessary documents to accept said proposal; and

BE IT FURTHER RESOLVED that Town Comptroller Mary Ann Maxwell is hereby authorized to make any budgetary transfers or modifications required pursuant to this authorization.

Resolution

Offered by: _____

Seconded by: _____

<u>Roll Call Vote</u>	<u>YES</u>	<u>NO</u>
Stephen Baranowski	_____	_____
Frank Lombardi	_____	_____
Suzanne McDonough	_____	_____
Robert Schanil	_____	_____
Michael Cazzari	_____	_____

RESOLUTION #4

RESOLUTION ACKNOWLEDGING EMERGENCY REPAIRS/SERVICES CARMEL WATER AND SEWER DISTRICTS

RESOLVED, the Town Board of the Town of Carmel, acting as Commissioners of the various water and sewer districts of the Town of Carmel, hereby acknowledges the emergency performance of water and sewer district collection system/distribution system and treatment facilities repairs as fully detailed in the memorandum of Town Engineer Richard J. Franzetti, P.E. to the Town Board dated June 2, 2022, as attached hereto and made a part thereof.

Resolution

Offered by: _____

Seconded by: _____

<u>Roll Call Vote</u>	<u>YES</u>	NO
Stephen Baranowski	_____	_____
Frank Lombardi	_____	_____
Suzanne McDonough	_____	_____
Robert Schanil	_____	_____
Michael Cazzari	_____	_____

Richard J. Franzetti, P.E.
Town Engineer



(845) 628-1500
(845) 628-2087
Fax (845) 628-7085

Office of the Town Engineer
60 McAlpin Avenue
Mahopac, New York 10541

MEMORANDUM

To: Carmel Town Board

From: Richard J. Franzetti P.E. Town Engineer 

Date: June 2, 2022

Re: Emergency Repairs/Services

This memorandum is being presented to the Town Board to advise the Board of emergency invoices that were submitted for payment in excess of \$10,000.00 for services rendered. The following provides a brief a summary of the work that was performed.

- Carmel Water District 3

On April 21, 2022 Inframark, the operators of CWD 3, reported that well 5 in the vicinity of the CSD 4 treatment plant had stopped working. This the highest producing well for the district. Inframark contacted Bee and Jay plumbing to assess the failure and it was determined that the motor failed due to use. Attached is the invoice from Bee and Jay plumbing in the amount of \$16,338.75 for the replacement of the well pump.

- Carmel Water District 1

On May 14, 2022 Bee and Jay, the operators of CWD 1, reported a leak at the intersection of Cherry Street and Route 6N in downtown Mahopac. Three (3) valves at this location were found to be leaking. Attached is the invoice from Kuck Excavating in the amount of \$10,807.28 for the excavation and repair of the valves.

We request that this memorandum be put into the agenda as a matter of record.



P.O. Box 78 - 719 Route 6 - Mahopac, NY 10541

p: 845.628.3924 f: 845.628.4062

e: service@beeandjay.com

INVOICE

DATE	INVOICE #
4/25/2022	101316

www.BEEANDJAY.com

BILL TO:

Town Of Carmel- CWD 3
Engineering Dept.
60 McAlpin Ave.
Mahopac, NY 10541

SERVICE LOCATION:

CSD Sewer Plant
Booster Stations
Mahopac, NY

PROFESSIONAL SERVICE 58 YEARS 1964-2022

Master Plumbers Lic.#s W.C. 556 P.C. 363

CUSTOMER #	TERMS	MECHANIC	SERVICE DATE	WORK ORDER #
845 628 1500	Payment Due Upon Rec	EK	4/22/2022	68713
ITEM	QTY/HRS	DESCRIPTION	RATE	AMOUNT
Description		CWD# 3 Secor Sewer Plant Access Booster Station - Emergency: Low storage tested, found main well burnt out due to excessive usage, pulled 420 feet 10 hp 65 gs Goulds pump from well, replaced complete motor and pump assembly with subcable and all equipment, restored into system.		
Labor TOC Lab...	8	1-Laborer	140.00	1,120.00
Labor TOC Tech	8	1- Tech Plb	185.00	1,480.00
Material		1- 10 hp 460 Volt Motor	4,701.00	4,701.00
Material		1- 65GS100 Pump End	6,378.00	6,378.00
Material		1- 2" Line Check	206.00	206.00
Material		12- Rolls Tape	65.00	65.00
Material		2- Sets Heat Shrinks	44.00	44.00
Material		420 feet 10-4 Sub Cable	1,265.00	1,265.00
Material		1- 2x5 Brass Nipple	79.75	79.75
Boom Truck		Boom Truck	1,000.00	1,000.00
<i>Slk - emailed Donna - rec'd invoice?? emailed</i>				

** Invoices not paid when due will be subjected to a finance charge of 1.5% per month

Total Due \$16,338.75

WE ACCEPT ALL MAJOR CREDIT CARDS !!

CARD TYPE: VISA MASTERCARD AMERICAN EXPRESS DISCOVER DINER'S CLUB OTHER _____

CARDHOLDER/NAME: _____ SIGNATURE: _____

CARD# _____ EXP. DATE: _____ CID # _____

EMAIL: _____

EXHIBIT "B"

**Emergency Justification Form
Town of Carmel Procurement Policy**

Procurement Policy, Section VI: Emergency Procurement

Subdivision (4) of General Municipal Law §103 sets forth an exception to purchasing and bidding requirements for emergency situations

Department: Engineering

Vendor name: Bee and Jay

Nature of emergency: Emergency Pump Repair at Booster Station

Estimated cost: See attached

There are three basic statutory criteria to be met in order to fall within the emergency purchase exception. State the basis for identifying an emergency purchase or service, check any that apply:

- The situation arose out of an accident or unforeseen occurrence or condition.
- Public buildings, public property, or the life, health, safety or property of the political sub-division's residents were affected.
- The situation required immediate action, which could not await competitive bidding.
- The emergency purchases or services exceeded **\$10,000** and will be submitted to the Town Board for presentation at a Town Board Meeting to acknowledge said emergency. A Town Board Resolution should be passed acknowledging the same.
- Other (provide explanation):

Purchasing Agent's signature for approval: _____

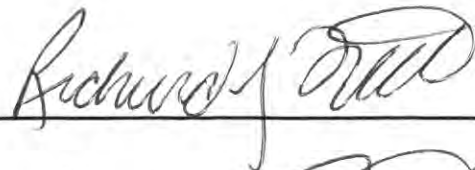

Department Head's signature for approval: _____

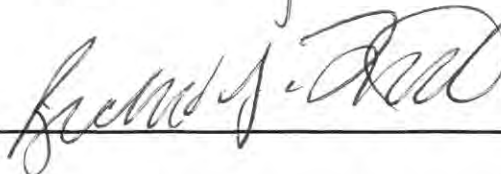

Ed Kuck Excavating Inc

20 Day Road
Carmel, NY 10512

INV # TOC-50-2022
c wd 1
REQ #
Vendor 0670
Tax ID - 133851002

Attention: ROB VARA, ENGINEERING
TOWN OF CARMEL

EMERGENCY 8" VALVES LEAKING/ ROTTEN BOLTS

Respond as per BEE & JAY
Job Location: CHERRY LANE
Work Completed; 5/14/2022
Start time:

End Time: 9 HRS PWOT

Job Description:

WATER LEAKING IN ROAD AT VALVE CLUSTER, SAW CUT ROAD, DUG AND EXPOSED 3-8" VALVES LEAKING, REPAVED ALL 3 INSIDES OF VALVES
BACKFILL AND COMPACT WITH ITEM 4
***NEEDS BLACKTOP RESTORATION**

Materials / Equipment/ Labor	Total Hrs,yds,qty	Price per yd, qty, day	Total
Track Hoe MR55	9	\$95.00 per hour	855.00
Dump Truck	9	\$100.00 per hour	900.00
Support Vehicle	Day rate	\$155.00 PER DAY	155.00
Chop Saw	Day rate	\$ 70.00	70.00
Jumping Jack	Day rate	\$70.00	70.00
Plate tamper	Day rate	\$70.00	
Mud Sucker	Day rate	\$70.00	70.00
Locater	Day rate	\$70.00	
Machine Hammer	Day rate	\$250.00	
Powered drill/hammer	Day rate	\$70.00	
Machine operator	9 Hrs X 1 MAN	\$276.27 PWOT PER HR	2,486.43
Laborers	9 HRS X 2 MEN	\$238.95 PWOT PER HR	4,301.10
LABORER	5 HRS 1 MAN PWOT	\$238.95 PER HR	1,194.75
Item 4	15 YARDS	\$47.00 per yard	705.00
Seed		\$150.00 bag	
Top soil		\$50.00	
Blacktop		\$139.00 per ton	
SHORING BOX		\$500.00	
Hay		\$19.00 bag	
GRAVEL		\$50.00/YARD	
Total			10,807.28



Office of the Town Engineer
60 McAlpin Avenue
Mohopac, New York 10541

WATER MAIN BREAK/DAMAGED HYDRANT REPORT

District & Number: CWA #1

Location (street address): 24-6N + ~~Cherry~~ CHERRY LN

Time and Date of Main Break or Hydrant Damage: 5/14/22

Field Response:

Manpower	HRS	Equipment	HRS
<u>Bull + Jim Alb</u>		<u>Hydrant Restoration</u>	
<u>Treat Alb</u>	<u>11</u>	<u>Breakdown/repair</u>	<u>9</u>
<u>Treat Alb</u>	<u>11</u>	<u>Dump Truck</u>	<u>9</u>
<u>Treat Alb</u>	<u>8</u>	<u>Crane</u>	<u>9</u>

Water Main: Size: 8" Material: PVC Depth to Main: 60"

Hydrant: Manufacturer & Model: _____

Repair Materials Utilized: Joint Down + Insulation System +
Partners Replacem 3"-THREE 8" GATE MET VALVE
Bonomet + Cast Copolymer + THIRTY

Cause of Main Break or Hydrant Damage: TWO OF (3) 8" MET GATE
VALVES ROTTEN BOLT + WRENCH BLEW OFF.

Description of Damage caused, if any: _____

Future Restoration Required:

Pavement:	<input checked="" type="checkbox"/>	Sidewalk:	<input type="checkbox"/>
Lawn Area:	<input type="checkbox"/>	Shrubs:	<input type="checkbox"/>

Cause of Main Break or Hydrant Damage: _____

Date Repair Completed: 5/14/22 Prepared by: [Signature]
(Printed Name)

RESOLUTION #5

**RESOLUTION AUTHORIZING ENTRY INTO AGREEMENT FOR
COPIER LEASE– TOWN OF CARMEL HIGHWAY DEPARTMENT**

WHEREAS, the Town Board of the Town of Carmel, upon the recommendation of Highway Superintendent, Michael Simone fully as detailed in his memo dated May 20, 2022, authorizes the entry into agreement with LEAF Financial Services, Moberly, MO, for a Kyocera 3212i Copier, commencing May 2022 at a cost not to exceed \$138.73 per month, plus a onetime processing fee of \$95.00 as indicated on the lease agreement dated May 19, 2022

BE IT FURTHER RESOLVED that the Town Comptroller MaryAnn Maxwell is hereby authorized to make any and all necessary budget revisions to effect the aforesaid lease transaction.

Resolution

Resolution

Offered by: _____

Seconded by: _____

<u>Roll Call Vote</u>	<u>YES</u>	<u>NO</u>
Stephen Baranowski	_____	_____
Frank Lombardi	_____	_____
Suzanne McDonough	_____	_____
Robert Schanil	_____	_____
Michael Cazzari	_____	_____

RESOLUTION #6

**RESOLUTION AUTHORIZING PURCHASE AND INSTALLATION OF GUIDERAILS –
TOWN OF CARMEL HIGHWAY DEPARTMENT**

RESOLVED that the Town Board of the Town of Carmel, upon the recommendation of Town of Carmel Town Highway Superintendent Michael Simone, hereby accepts the proposal of Chemung Supply Corporation, Elmira, NY for the purchase and installation of 2,000 feet of Guiderail at a cost not to exceed \$72,800.00, in accordance with the proposal/invoice dated May 25, 2022 and the authorization awarding the bid for said materials issued by the Town Board on November 17, 2021; and

BE IT FURTHER RESOLVED that the Town Board of the Town of Carmel accepts the proposal of Chemung Supply Corporation, Elmira, NY for the removal and reinstall of 800 feet of guiderail on Wixon Pond Road at a cost not to exceed \$17,037 per the Orange County Bid, Contract Number RFB-OC 121-21; and

BE IT FURTHER RESOLVED that Town Supervisor Michael Cazzari is hereby authorized to sign all necessary documents to accept said proposal; and

BE IT FURTHER RESOLVED that Town Comptroller Mary Ann Maxwell is hereby authorized to make any budgetary transfers or modifications required pursuant to this authorization.

Resolution

Offered by: _____

Seconded by: _____

<u>Roll Call Vote</u>	<u>YES</u>	<u>NO</u>
Stephen Baranowski	_____	_____
Frank Lombardi	_____	_____
Suzanne McDonough	_____	_____
Robert Schanil	_____	_____
Michael Cazzari	_____	_____

RESOLUTION #7

RESOLUTION SETTING RATES FOR 2022 SEASONAL EMPLOYEES LAKE SECOR PARK DISTRICT

RESOLVED that the Town Board of the Town of Carmel, acting as the Commissioners of the Lake Secor Park District, hereby sets the following rates for Lifeguards in 2022.

<u>POSITION</u>	<u>MAXIMUM RATE OF PAY</u>
Head Lifeguard	\$20.00/hr.
Life Guards	\$17.50/hr.
New Life Guards	\$15.00/hr.

Resolution

Offered by: _____

Seconded by: _____

<u>Roll Call Vote</u>	<u>YES</u>	<u>NO</u>
Stephen Baranowski	_____	_____
Frank Lombardi	_____	_____
Suzanne McDonough	_____	_____
Robert Schanil	_____	_____
Michael Cazzari	_____	_____

RESOLUTION #8

RESOLUTION AUTHORIZING ADDITIONS AND DELETIONS TO THE ACTIVE LIST OF THE MAHOPAC VOLUNTEER FIRE DEPARTMENT

RESOLVED that the Town Board of the Town of Carmel hereby authorizes the additions of the following names from the active list of the Mahopac Volunteer Fire Department:

SAMUEL PRZYMYLSKI, MAHOPAC, NY
MICHAEL AURISICHIO, MAHOPAC, NY
ALBERT KRASNIQU, MAHOPAC, NY
JUSTIN VIALIZ, MAHOPAC, NY

AND

JAMIE FIELDALE, CARMEL, NY

BE IT FURTHER RESOLVED that the Town Board of the Town of Carmel hereby authorizes the deletion of the following name from the active list of the Mahopac Volunteer Fire Department:

KIERAN SULLIVAN

Resolution

Offered by: _____

Seconded by: _____

Roll Call Vote	YES	NO
Stephen Baranowski	___	___
Frank Lombardi	___	___
Suzanne McDonough	___	___
Robert Schanil	___	___
Michael Cazzari	___	___

RESOLUTION #9

ORDER CALLING PUBLIC HEARING IN THE MATTER OF THE INCREASE AND IMPROVEMENT OF THE FACILITIES OF CONSOLIDATED SEWER DISTRICT #5, IN THE TOWN OF CARMEL, PUTNAM COUNTY, NEW YORK

WHEREAS, the Town Board of the Town of Carmel, Putnam County, New York, has caused to be prepared a map, plan and report, including an estimate of cost, pursuant to Section 202-b of the Town Law, relating to the increase and improvement of the facilities of Consolidated Sewer District #5, in the Town of Carmel, Putnam County, New York (the "Sewer District"), being the replacement in kind on site of the existing Wastewater Treatment Plant, including original furnishings, equipment, machinery, apparatus, appurtenances, and incidental improvements and expenses in connection therewith, at a maximum estimated cost of \$1,018,690; and

WHEREAS, the capital project hereinafter described, as proposed, has been determined to be a Type II Action pursuant to the regulations of the New York State Department of Environmental Conservation promulgated pursuant to the State Environmental Quality Review Act, which regulations state that Type II Actions will not have any significant adverse impact on the environment; and

WHEREAS, it is now desired to call a public hearing on the question of the increase and improvement of the facilities of said Sewer District, in the matter described above, and to hear all persons interested in the subject thereof, concerning the same, in accordance with the provisions of Section 202-b of the Town Law;

NOW, THEREFORE, IT IS HEREBY ORDERED, by the Town Board of the Town of Carmel, Putnam County, New York, as follows:

Section 1. A public hearing will be held in the Town Hall, in Mahopac, New York, in said Town, on July 6, 2022, at 7:00 o'clock P.M., Prevailing Time, on the question of the increase and improvement of the facilities of Consolidated Sewer District #5, in the Town of Carmel, Putnam County, New York, in the manner described in the preambles hereof, and to hear all persons interested in the subject thereof, concerning the same, and to take such action thereon as is required or authorized by law.

Section 2. The Town Clerk is hereby authorized and directed to cause a copy of the Notice of Public Hearing hereinafter provided to be published once in the official newspaper, and also to cause a copy thereof to be posted on the sign board of the Town, such publication and posting to be made not less than ten, nor more than twenty, days before the date designated for the hearing.

Section 3. The notice of public hearing shall be in substantially the form attached hereto as Exhibit A and hereby made a part hereof.

Section 4. This Order shall take effect immediately.

Resolution

Offered by: _____

Seconded by: _____

<u>Roll Call Vote</u>	<u>YES</u>	<u>NO</u>
Stephen Baranowski	_____	_____
Frank Lombardi	_____	_____
Suzanne McDonough	_____	_____
Robert Schanil	_____	_____
Michael Cazzari	_____	_____

CERTIFICATION FORM
STATE OF NEW YORK)
) ss.:
COUNTY OF PUTNAM)

I, the undersigned Clerk of the Town of Carmel, Putnam County, New York (the “Issuer”), DO
HEREBY CERTIFY:

1. That a meeting of the Issuer was duly called, held and conducted on the 15th day of June, 2022.
2. That such meeting was a **special regular** (circle one) meeting.
3. That attached hereto is a proceeding of the Issuer which was duly adopted at such meeting by the Board of the Issuer.
4. That such attachment constitutes a true and correct copy of the entirety of such proceeding as so adopted by said Board.
5. That all members of the Board of the Issuer had due notice of said meeting.
6. That said meeting was open to the general public in accordance with Section 103 of the Public Officers Law, commonly referred to as the “Open Meetings Law”.
7. That notice of said meeting (*the meeting at which the proceeding was adopted*) was caused to be given **PRIOR THERETO** in the following manner:

PUBLICATION (here insert newspaper(s) and date(s) of publication - should be a date or dates falling prior to the date set forth above in item 1)

POSTING (here insert place(s) and date(s) of posting- should be a date or dates falling prior to the date set forth above in item 1)

IN WITNESS WHEREOF, I have hereunto set my hand and affixed the seal of the Issuer this
_____ day of June, 2022.

Town Clerk

(CORPORATE SEAL)

NOTICE OF PUBLIC HEARING

NOTICE IS HEREBY GIVEN that the Town Board of the Town of Carmel, Putnam County, New York, will meet at 60 McAlpin Avenue, in Mahopac, New York and also via Zoom, in Mahopac, New York, in said Town, on July 6, 2022, at _____ o'clock P.M., Prevailing Time, for the purpose of conducting a public hearing upon a certain map, plan and report, including an estimate of cost, in relation to the proposed increase and improvement of the facilities of the Consolidated Sewer District #5, in said Town, being the replacement in kind on site of the existing Wastewater Treatment Plant, including original furnishings, equipment, machinery, apparatus, appurtenances, and incidental improvements and expenses in connection therewith, at a maximum estimated cost of \$1,018,690.

Remote public participation will be available as follows:

Said capital project has been determined to be a Type II Action pursuant to the regulations of the New York State Department of Environmental Conservation promulgated pursuant to the State Environmental Quality Review Act ("SEQRA"), the implementation of which as proposed, as such will not result in any significant environmental impact.

At said public hearing said Town Board will hear all persons interested in the subject matter thereof.

Dated: Mahopac, New York,
June _____, 2022.

BY ORDER OF THE TOWN BOARD OF THE TOWN OF
CARMEL, PUTNAM COUNTY, NEW YORK

/s/Ann Spofford
Town Clerk

RESOLUTION #10

RESOLUTION ACCEPTING DONATION OF VACATION TIME BY TOWN OF CARMEL EMPLOYEE

RESOLVED that the Town Board of the Town of Carmel approves the donation of up to 25 vacation days from Employee #1699 to Employee #2842, as is on file within the Office of the Town Supervisor.

Resolution

Offered by: _____

Seconded by: _____

<u>Roll Call Vote</u>	<u>YES</u>	<u>NO</u>
Stephen Baranowski	_____	_____
Frank Lombardi	_____	_____
Suzanne McDonough	_____	_____
Robert Schanil	_____	_____
Michael Cazzari	_____	_____

RESOLUTION #11

RESOLUTION AUTHORIZING SCHEDULING OF PUBLIC HEARING

RESOLVED that the Town Board of the Town of Carmel hereby authorizes the scheduling of a Public Hearing at Town Hall, 60 Mc Alpin Avenue, Mahopac, New York 10541 on Wednesday July 13, 2022 at 7:00 p.m. or as soon thereafter that evening as possible, on a proposed Local Law which is proposing multiple amendments to Chapter 156 of the Code of the Town of Carmel, entitled "Zoning" and

BE IT FURTHER RESOLVED that Town Clerk Ann Spofford is hereby authorized and instructed to publish and post the necessary notices in the official newspaper of the Town and on the Town bulletin board regarding this Public Hearing.

Resolution

Offered by: _____

Seconded by: _____

<u>Roll Call Vote</u>	<u>YES</u>	<u>NO</u>
Stephen Baranowski	___	___
Frank Lombardi	___	___
Suzanne McDonough	___	___
Robert Schanil	___	___
Michael Cazzari	___	___

RESOLUTION AUTHORIZING SCHEDULING OF PUBLIC HEARING

RESOLVED that the Town Board of the Town of Carmel hereby authorizes the scheduling of a Public Hearing at Town Hall, 60 Mc Alpin Avenue, Mahopac, New York 10541 on Wednesday July 20, 2022 at 7:00 p.m. or as soon thereafter that evening as possible, pursuant to New York Town Law §272-A and §272-A(6) on the Draft Comprehensive Plan being proposed in and for the Town of Carmel; and

BE IT FURTHER RESOLVED that Town Clerk Ann Spofford is hereby authorized and instructed to publish and post the necessary notices in the official newspaper of the Town and on the Town bulletin board regarding this Public Hearing.

Resolution

Offered by: _____

Seconded by: _____

<u>Roll Call Vote</u>	<u>YES</u>	<u>NO</u>
Stephen Baranowski	___	___
Frank Lombardi	___	___
Suzanne McDonough	___	___
Robert Schanil	___	___
Michael Cazzari	___	___

TB/WS 6-15-2022 AGENDA ITEM #1



TOWN OF CARMEL RECREATION & PARKS DEPARTMENT
SYCAMORE PARK, 790 LONG POND ROAD
MAHOPAC, NEW YORK 10541

JAMES R. GILCHRIST, CPRP, DIRECTOR

TELEPHONE: (845) 628-7888 FAX: (845) 628-2820

EMAIL: carmelrecreation@ci.carmel.ny.us

WEB: <http://www.carmelny.org>

DATE: June 7, 2022

TO: Carmel Town Board
Carmel Town Hall

FROM: James R. Gilchrist, CPRP
Director, Recreation and Parks

SUBJECT: Eagle Scout Project – Informational Nature Signs at Sycamore Park

Eagle Scout candidate Max Head from Mahopac Troop 1 has proposed to install (5) informational signs about local plant life at Sycamore Park. The signs will be made of thick aluminum and mounted on 4x4 pressure treated posts.

Attached is an outline Max submitted for review at Thursday night's Recreation and Parks Advisory Committee Meeting. This proposal was reviewed and unanimously approved by all members.

Please add this to the June 15th Town Board work session agenda and contact me with any questions.

/nls
Attachment

Project Proposal

Proposal.

Install five informational signs around the park that will depict and describe seven thorn and/or fruit bearing plants found in the park. The goal of these signs is to improve the overall experience of park goers by providing greater information about the local plant life and warning of the potential hazards of contact with these plants.

Locations:

Signs will be located in circled areas of the park



- 2 signs near the park entrance
- 1 sign next to the Gaga pit
- 1 sign next to the handball court
- 1 sign near the northern edge of the upper field

Sign Descriptions:

The signs will be made of 2mm thick aluminum, 3 signs will be 6x8 inches and 2 signs will be 12x8 inches. The signs will be mounted on either a 7x9 or a 13x9 backboard and a 4x4 post, both made of pressure treated wood. The sign posts will be buried 3ft below the ground and protrude 4ft above the soil. The signs will be slanted at a 45 degree angle and display a custom design with information about the plant and a depiction of the plant. The backboards will be affixed to the sign posts with galvanized screws and the signs themselves will be affixed to the backboards with galvanized bolts. The signs will be anchored with a cylindrical concrete base that is 10" in diameter and encases the buried portion of the sign post. There will be a 3" gravel base for the sign post anchor and the sign base will be topped with mulch.

Sign example:

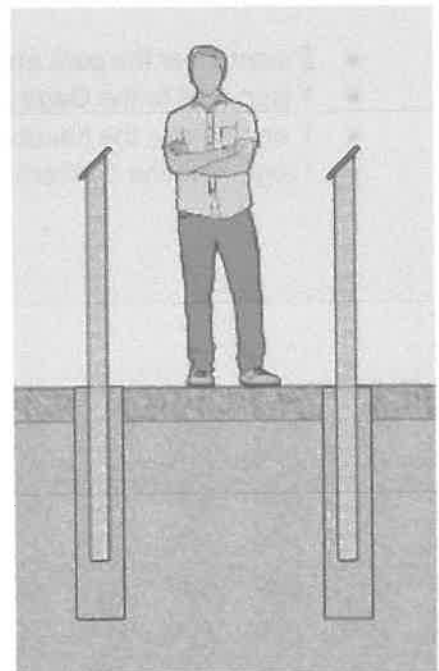
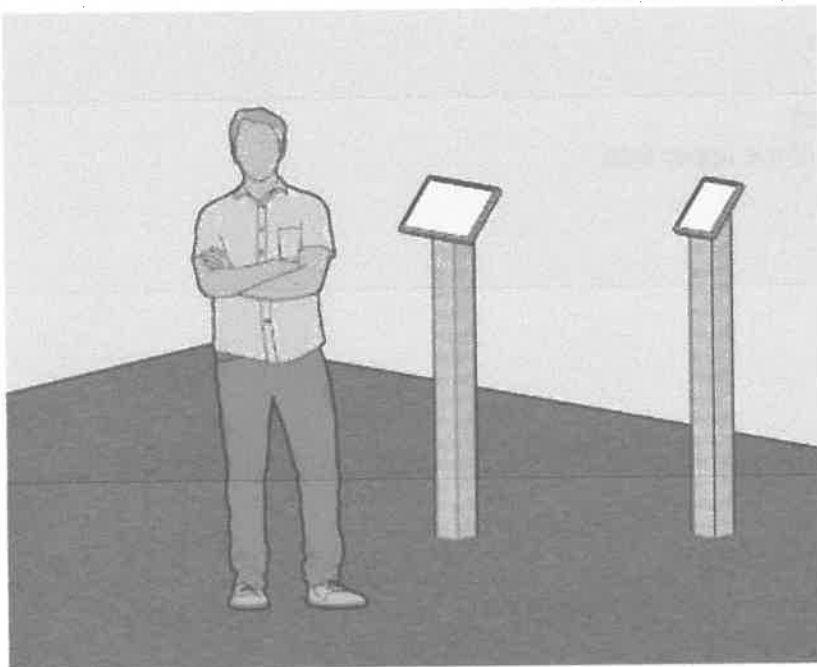
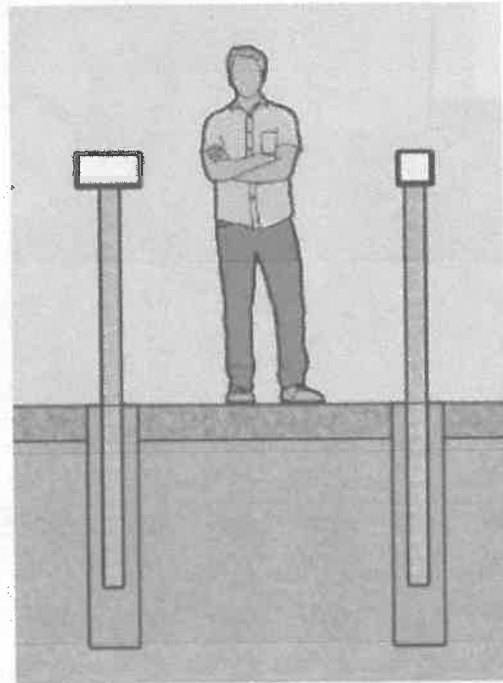
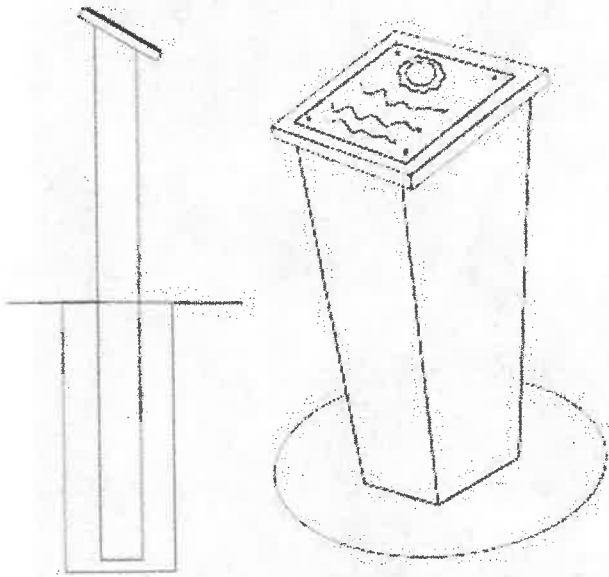

Sign Graphic Example

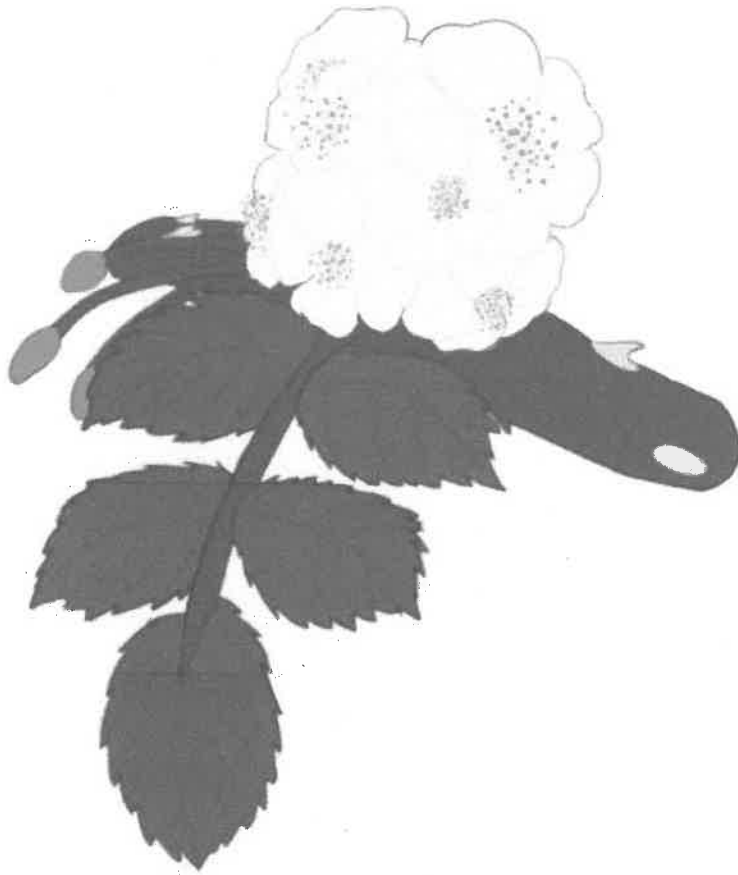

Sign Contents:

- Plant Name English/Latin
- Native Origins
- Hazards:
 - Thorns
 - Fruit bodies
 - Edibility

Project Description and Benefit

Briefly describe your project

Install five informational signs around Sycamore park that will provide information on seven thorn and/or fruit bearing plants found in the park. The signs will be made of 2mm thick aluminum, 3 signs will be 6x8 inches and 2 signs will be 12x8 inches. The signs will be mounted on either a 7x9 or a 13x9 backboard and a 4x4 post, both made of pressure treated wood. The sign posts will be buried 3ft below the ground and protrude 4ft above the soil. The signs will be slanted at a 45 degree angle and display a custom design with information about the plant and a depiction of the plant. The backboards will be affixed to the sign posts with galvanized screws and the signs themselves will be affixed to the backboards with galvanized bolts. The signs will be anchored with a cylindrical concrete base that is 10" in diameter and encases the buried portion of the sign post. There will be a 3" gravel base for the sign post anchor and the sign base will be topped with mulch.

Include images on an additional document.

Tell how your project will be helpful to the beneficiary. Why is it needed?

The goal of these signs is to improve the overall experience of park goers by providing greater information about the local plant life and warning of potential hazards of contact with these plants. These signs will also increase public investment in the park by increasing public awareness of the flora of the park.

When do you plan to begin carrying out your project?

Mid July

When do you think your project will be completed?

Late Summer or Early Fall

Giving Leadership

Approximately how many people will be needed to help on your project?

Where will you recruit them (unit members, friends, neighbors, family, others)?

Work helpers will likely be recruited from my troop or friend groups

What do you think will be most difficult about leading them?

Keeping my team focused on performing the task at hand in an efficient and timely manner will be the most difficult aspect of leading them

Materials

Materials are things that become part of the finished project, such as lumber, nails and paint.

What types of materials, if any, will you need? You do not need a detailed list or exact quantities, but you must show you have a reasonable idea of what is required. For example, for lumber, use basic dimensions such as 2x4 or 4x4.

- Concrete Mix 250lbs
- 4x4 8ft pressure treated wood posts 5x
- Pressure treated wood boards 5x
- Galvanized screws & bolts
- Mulch 3 bags
- Gravel 6 bags
- Sonotubes 5x
- Spray-paint

Supplies

Supplies are things you use up, such as food and refreshments, gasoline, masking tape, tarps, safety supplies and garbage bags.

What types of supplies, if any, will you need? You do not need a detailed list or exact quantities, but you must show you have a reasonable idea of what is required.

- Air Filtration Masks
- Garbage Bags
- First Aid Kit
- Food & Water
- Work Gloves
- Wheel Barrow
- Home Depot Buckets

Tools

Include tools, and also equipment, that will be borrowed, rented, or purchased.

What tools or equipment, if any, will you need? You do not need a detailed list, but you must show you have a reasonable idea of what is required.

- Shovels / Posthole diggers
- Measuring Tape
- Rake
- Power Drill
- Power Saw
- Level

Other Needs

Items that don't fit the above categories; for example, parking or postage, or services such as printing or pouring concrete, etc..

What other needs do you think you might encounter?

- Sign Printing Service
- Signs.com

Permits and Permissions

Note that property owners should obtain and pay for permits.

Will permissions or permits (such as building permits) be required for your project? Who will obtain them? How long will it take?

Construction permission from the recreation and parks department must be obtained before construction can begin

Preliminary Cost Estimate

You do not need exact costs yet. Reviewers will just want to see if you can reasonably expect to raise enough money to cover an initial estimate of expenses. Include the value of donated materials, supplies, tools, and other items. It is not necessary to include the value of tools or other items that will be loaned at no cost. Note that if your project requires a fundraising application, you do not need to submit it with your proposal.

Enter your estimated expenses below
(include sales tax if applicable)

Materials:	\$275.5
Supplies:	\$19
Tools:	\$0
Other:	\$100.86
Total Costs:	\$395.36

Fundraising: Explain how you will raise the money to pay for the total costs. If you intend to seek donations of actual materials, supplies, etc., then explain how you plan to do that, too.

I intend to seek monetary donations online through online fundraising activities

Project Phases

Think of your project in terms of phases, and list what they might be. The first may be to prepare your project plan. Other phases might include fundraising, preparation, execution and reporting. You may have as many phases as you want, but it is not necessary to become overly complicated; brief, one line descriptions are sufficient. If you have more than 10 phases, attach a separate page with your continued phase list.

1	Prepare project planning and obtain approval from council and beneficiary
2	Plan out fundraising strategy and obtain approval
3	Obtain funding through fundraising
4	Design sign faces and layouts
5	obtain sign materials, equipment, and supplies
6	Obtain building permits
7	prepare site and initiate construction
8	document construction and prepare report
9	
10	

Logistics

How will you handle transportation of materials, supplies, tools, and helpers?

Materials, supplies, and tools can be transported via automobile. Helpers will likely arrive through their own vehicles but arrangements can be made to provide transportation for them if they do not have a vehicle available.

Safety Issues

The Guide to Safe Scouting is an important resource in considering safety issues.

Describe the hazards and safety concerns of which you and your helpers should be aware.

Read the "Age Guidelines for Tool Usage" at Scouting.org

Heavy and sharp tool usage should be designated to adults and older scouts exclusively. Protective gear will be provided to helpers if they do not have them. Power tools will be used solely by adults. Amenities will be provided to protect helpers from heat and sun exposure. First aid will be ready at all times during construction. Adult supervision will be present at all times during construction.

Project Planning

You do not have to list every step, but it must be enough to show you have a reasonable idea of how to prepare your plan.

List some action steps you will take to prepare your project plan. For example, "Complete a more detailed set of drawings."

- Prepare fundraising presentation
- Establish construction limitations and permit requirements with park management
- Create a more detailed sign example graphic
- Create the graphics for the other signs

TB-WS6-15-2022 AGENDA ITEM #2



Richard J. Franzetti, P.E.
Town Engineer

(845) 628-1500
(845) 628-2087
Fax (845) 628-7085

Office of the Town Engineer
60 McAlpin Avenue
Mahopac, New York 10541

MEMORANDUM

To: Carmel Town Board

From: Richard J. Franzetti P.E. Town Engineer 

Date: June 14, 2022

Re: C 285- Chemical Supply to various water and sewer districts

Bids were received for the referenced supply contract on June 10, 2022. The Bids were opened by the Town Clerk. A copy of the bid opening results is attached. The scope of work involves chemical supply to various Town of Carmel water and sewer districts.

I. RECOMMENDATIONS BASED UPON CURRENT BID PRICING

Three (3) bids were tabulated as identified on the attached spread sheet. Based on the results the following recommendations are made:

The total annual award to Slack, based on the estimated quantities identified in the contract documents would be \$247,553.82. It should be noted that this is an estimate only and is based on actual consumption.

Coyne Chemical was the lowest bidder on Item #6-CSD#7, Item #1- CSD#2 and Item #2-CWD#8, however, as provided in the attached, Coyne conditioned the delivery times indicating delivery times of 7-10 business days from packaged product delivery and 10-14 days for Bulk Delivery. The contract specifications clearly call for delivery within forty-eight (48) hours of the order. The variation of this requirement is considered material. The specifications provide that "Conditional or qualified bids will not be accepted" (A. -9) and therefore the Coyne bid must therefore be rejected.

PVS provided pricing only on item #5- Caustic Soda 25%, which if awarded would represent and annual saving of \$848.70 (\$5,862.70-\$5,014.00), which would amount to 0.34 percent of the entire costs over a single year. This Department believes that an award on this single item would not offset the office inefficiencies it would create by dealing with this separate vendor for this small item.

Chemicals for the Districts are included as part of the annual budget. However, due to the increase in costs, it is probable that several districts will go over budget for year ending 2022. As such, budget revision transfer requests will be required. Budgeting for 2023 will include the cost increase for these chemicals.

June 14, 2022

C 285- Chemical Supply to various water and sewer districts

II. FAILURE TO ACKNOWLEDGE ADDENDUM

Slack Chemical failed to acknowledge Addendum #1. As a general procedure, a failure to acknowledge an addendum would render the submitted bid defective and would necessitate outright rejection of that bid.

While this is not a statutory requirement, it is consistent with the intention of competitive bidding which is required under GML § 104 to the extent that a failure to acknowledge an addendum, materially alters a bid, where consideration of that bid would usurp the competitive nature of the public bidding process. For instance, an addendum which adds an extra bid item, that goes unacknowledged by a bidder would create an uneven bidding environment, and any communication with that bidder, seeking bid pricing on that item AFTER the bid opening, would prejudice all other compliant bidders and would arguable put the Town into a position of negotiator as opposed to independent receptacle of bids which is the intention of GML § 104.

This however is not the case in the present situation. The bid specifications failed to include two (2) forms. A "BID BOND" form and a "CONSENT OF SURETY" form. The two (2) forms are used by bidders in the event that they choose the bid bond **option** as a means of guaranteeing that if the bid is accepted, the contract will be entered into. This however is only one (1) option that could be used, the other option is to submit a certified check for 5% (five) of the total amount bid. In submitting its bid, Slack chose to submit certified checks as a guarantee. So even if Slack had acknowledged the addendum, it would not have utilized the forms.

Based upon the above, we consider the failure to acknowledge addendum #1 by Slack to be of a non-material nature and as such, we suggest that the Boards consideration of Slack's bid does not violate the intention or the text of GML § 104.

III. CURRENT CONTRACTS WITH UNILATERAL OPTIONS TO RENEW

The Board should be aware that the Town currently has three (3) contracts for Chemical supplies with Brenntag Surpass and Coyne. Each of these contracts expires in July of 2022, with the Town holding a unilateral option to renew for one (1) year. The attached letter from Surpass indicating that they would be unwilling to proceed with a second year of fulfillment as chemical costs have increased anywhere from "10-300 %".

In an effort to verify or refute that position and after discussion with the Town Attorney, this Department sought authorization from the Board to go out to bid on the chemical supplies while keeping the renewal option. Based upon the bids received which are the best objective representation of the regional market value of the goods, this Department believes the assertion in the Surpass letter is supported. As identified on the spread sheet the average increase in chemical prices by the lowest responsive bidder, Slack, shows an increase of 87% over the previous year's pricing. At this point it would be ill advised to pursue the options as the fulfillment of supplies based upon last years, pricing, given the dramatic increases in cost, will likely result in repudiation and ultimately delivery failure, which is not an option when it comes to supply of chemical that are critical to the process of both the water and sewer treatment plant.

Therefore, this Department recommend that the options not be pursued and by virtue of the above recommended award, the options will terminate by operation of law.

I respectfully request that this matter be placed on the next available work session for discussion.

Engineering Bid C-285 – Chemical & Diatomaceous Earth Supply For Town of Carmel Water and Sewer Districts

Bid Opening June 10, 2022 @ 11:00 AM

	Company Name	Address	NCBS	Bid Bond/ Check	Receipt of Addendum Acknowledged
1.	Slack Chemical Co Inc.	465 S Clinton Street Carthage, NY 13619	✓	8 Checks	No
2.	PVS Mini bulk, Inc	10900 Harper Avenue Detroit, MI 48213	✓	✓	✓
3.	George S Coyne Chemical Co.	3015 State Road Croydon, PA 19021	✓	✓	✓
4.					
5.					

CSD #2 WWTP at Old Route 6, Carmel (Carmel Hamlet)

Material	Estimated quantity	Bidder #1	Bidder #2	Bidder #3	Bidder #4	Bidder #5
Item # 5 Caustic Soda 25%	2,300 gallons Unit Price Bid	2.549	2.18	—		
	Price X Estimated Quantity	5,862.70	5,014.00	—		
Item #4 Caustic Soda 50%	2,700 gallons Unit Price Bid	4.798	—	—		
	Price X Estimated Quantity	12,954.60	—	—		
Item #7 Sulfuric Acid 50%	1,600 gallons Unit Price Bid	7.984	—	8.57		
	Price X Estimated quantity	12,774.40	—	13,712.00		
Item #8 Citric Acid	50 gallons Unit Price Bid	9.479	—	—		
	Price X Estimated quantity	473.95	—	—		

CSD #4 WWTP at North Road, Mahopac (Lake Secor Sewer District)

Material	Estimated Quantity	Bidder #1	Bidder #2	Bidder #3	Bidder #4	Bidder #5
Item #7 Sulfuric Acid 50%	60 gallons Unit Price Bid	7.984	—	14.12		
	Price X Estimated quantity	479.04	—	847.20		
Item #4 Caustic Soda 50%	275 gallons Unit Price Bid	4.798	—	—		
	Price X Estimated quantity	1,319.45	—	—		
Item # 8 Citric Acid 50%	75 gallons Unit Price Bid	9.479	—	—		
	Price X Estimated quantity	710.93	—	—		

CSD #5 WWTP at Carey St, Mahopac (Hillsdale Sewer District)

Material	Estimated Quantity	Bidder #1	Bidder #2	Bidder #3	Bidder #4	Bidder #5
Item # 2 Chlorine	600 gallons Unit Price Bid	4.29	————	11.6452		
	Price X Estimated quantity	2,574.00	————	6,987.12		

CSD #6 WWTP at Vineland Road, Mahopac (Ivy Hills Sewer District)

Material	Estimated Quantity	Bidder #1	Bidder #2	Bidder #3	Bidder #4	Bidder #5
Item # 2 Chlorine	250 gallons Unit Price Bid	4.29	————	19.7856		
	Price X Estimated quantity	1,072.50	————	4,946.40		

CSD #7 WWTP at Dahlia Drive, Mahopac (Buckshollow Sewer District)

Material	Estimated Quantity	Bidder #1	Bidder #2	Bidder #3	Bidder #4	Bidder #5
Item # 6 Aluminum chlorohydrate	750 gallons Unit Price Bid	10.75	————	9.35		
	Price X Estimated quantity	8,062.50	————	7,012.50		
Item 2 Chlorine	30 gallons Unit Price Bid	4.08	————	19.2213		
	Price X Estimated quantity	122.40	————	576.64		
Item # 8 Citric Acid (50%)	35 gallons Unit Price Bid	10.99	————	————		
	Price X Estimated quantity	384.65	————	————		

CWD#2 WTP at 1744 Route 6, Carmel, New York (Carmel Hamlet)

Material	Estimated Quantity	Bidder #1	Bidder #2	Bidder #3	Bidder #4	Bidder #5
Item # 1 Phosphoric acid	3,000 gallons Unit Price Bid	26.39	—————	22.9695		
	Price X Estimated quantity	79,170.00	—————	68,907.60		
Item # 2 Chlorine	8,500 gallons Unit Price Bid	2.849	—————	—————		
	Price X Estimated quantity	24,216.50	—————	—————		
Item # 3 Diatomaceous earth	65,000 pounds Unit Price Bid	1.095	—————	—————		
	Price X Estimated quantity	71,175.00	—————	—————		

CWD#3 WTP - 105 Spring Road, Mahopac, New York

Material	Estimated Quantity	Bidder #1	Bidder #2	Bidder #3	Bidder #4	Bidder #5
Item#2 Chlorine	600 gallons Unit Price Bid	4.29	—————	—————		
	Price X Estimated quantity	2,574.00	—————	—————		

CWD#8 WTP - 71 Heather Drive, Mahopac, New York

Material	Estimated Quantity	Bidder #1	Bidder #2	Bidder #3	Bidder #4	Bidder #5
Item #2 Chlorine	1,800 gallons Unit Price Bid	9.99	—————	5.2923		
	Price X Estimated quantity	17,982.00	—————	9,526.14		
Item #2 Chlorine in gallon containers	460 gallons Unit Price Bid	6.49	—————	—————		
	Price X Estimated quantity	2,985.40	—————	—————		

CWD#12 WTP- 77 Jennifer Lane, Mahopac, New York

Material	Estimated Quantity	Bidder #1	Bidder #2	Bidder #3	Bidder #4	Bidder #5
Item #2 Chlorine	620 gallons Unit Price Bid	4.29	—	15.2031		
	Price X Estimated quantity	2,659.80	—	9,425.92		

C285 Chemical Supply ~ Bid Analysis

	Avail Budget	Proj Year End Forecast	Budget Balance
601	3,582	1,479	2,103
602	17,288	46,321	(29,032)
603	2,800	1,373	1,427
608	8,765	8,212	553
610	3,089	3,417	(328)
612	3,000	1,372	1,628
613	2,040	2,248	(208)
705	3050.72	686	2,364
706	1850	686	1,164
micro2	53080.5	52,111	969
micro4	5560.93	7,563	(2,002)
micro7	10446.89	6,203	4,244

District	Item #	MOD	Chemical	CURRENT PRICING						Bid Results						
				Coyne		Brenntag Northeast		Surpass		Slack			PVS		Coyne	
				Unit Cost	Ext Cost	Unit Cost	Ext Cost	Unit Cost	Ext Cost	Unit Cost	Ext Cost	% Increase	Unit Cost	Ext Cost	Unit Cost	Ext Cost
csd2	#5	gallons	caustic soda 25%	-	-	-	-	1.3380	3,077.40	2.549	5,862.70	91%	2.180	5,014.00	-	-
csd2	#4	gallons	caustic soda 50%	-	-	-	-	3.1620	8,537.40	4.798	12,954.60	52%			-	-
csd2	#7	gallons	sulfuric acid	5.5191	8,830.56	-	-	-	-	7.987	12,774.40	45%			8.570	13,712.00
csd2	#8	gallons	citric acid			-	-	5.6480	282.40	9.479	473.95	68%			-	-
csd4	#7	gallons	sulfuric acid	7.2412	434.47	-	-	-	-	7.984	479.04	10%			14.120	847.20
csd4	#4	gallons	caustic soda 50%			-	-	3.1620	869.55	4.798	1,319.45	52%			-	-
csd4	#8	gallons	citric acid			-	-	5.6480	423.60	9.479	710.93	68%			-	-
csd5	#2	gallons	chlorine (carboys ~ summer)			-	-	2.4580	1,474.80	4.290	2,574.00	75%			11.645	6,987.12
csd6	#2	gallons	chlorine (carboys ~ summer)			-	-	2.4580	614.50	4.290	1,072.50	75%			19.786	4,946.40
csd7	#6	gallons	aluminum chlorohydrate			-	-	4.3580	3,268.50	10.750	8,062.50	147%			9.350	7,012.50
csd7	#2	gallons	chlorine			-	-	4.5980	137.94	4.080	122.40	-11%			19.221	576.64
csd7	#8	gallons	citric acid			-	-	6.1480	215.18	10.990	384.65	79%			-	-
cwd2	#1	gallons	phosphoric acid			-	-	7.6160	22,848.00	26.390	79,170.00	247%			22.969	68,907.60
cwd2	#2	gallons	chlorine			-	-	1.4880	12,648.00	2.849	24,216.50	91%			-	-
cwd2	#3	lbs	diatomaceous earth			0.8190	52,975.00	-	-	1.095	71,175.00	34%			-	-
cwd3	#2	gallons	chlorine			-	-	2.4580	1,474.80	4.290	2,574.00	75%			-	-
cwd8	#2	gallons	chlorine			-	-	2.4880	4,478.40	9.990	17,982.00	302%			5.292	9,526.14
cwd8	#2	gallons	chlorine			-	-	3.3750	1,552.50	6.490	2,985.40	92%			-	-
cwd12	#2	gallons	chlorine			-	-	2.4580	1,523.96	4.290	2,659.80	75%			15.203	9,425.92

87%



Contract 285- Chemical Supply



BID FORM

CSD #2 WWTP at Old Route 6, Carmel (Carmel Hamlet)

4 drums minimum

Material	Estimated quantity	Unit Price Bid dollars	Unit Price Bid words	Extension Bid price X Estimated quantity
Item # 5 Caustic Soda 25%	2,300 gallons	\$ No Bid		\$
Item #4 Caustic Soda 50%	2,700 gallons	\$ No Bid		\$
Item #7 Sulfuric Acid 50%	1,600 gallons	\$ 8.57/gal	Eight dollars and fifty-seven hundredths cents	\$ 13,712.00
Item #8 Citric Acid	50 gallons	\$ No Bid		\$

CSD #4 WWTP at North Road, Mahopac (Lake Secor Sewer District)

Material	Estimated Quantity	Unit Price Bid dollars	Unit Price Bid words	Extension Bid Price X Estimated quantity
Item #7 Sulfuric Acid 50%	60 gallons	\$ 14.12/gal	Fourteen dollars and twelve hundredths cents	\$847.20
Item #4 Caustic Soda 50%	275 gallons	\$ No Bid		
Item # 8 Citric Acid 50%	75 gallons	\$ No Bid		

CSD #5 WWTP at Carey St, Mahopac (Hillsdale Sewer District)

Material	Estimated Quantity	Unit Price Bid dollars	Unit Price Bid words	Extension Bid Price X Estimated quantity
Item # 2 Chlorine	600 gallons	\$11.6452/gal	Eleven dollars and six thousand four hundred fifty-two ten thousandths cents	\$ 6,987.12

The George S. Coyne Chemical Co., Inc. is bidding with the understanding that our delivery terms are 7-10 business days ARO for packaged product delivery and 10-14 business days ARO for bulk product delivery. We take exception to any other stated delivery terms expressed within the bidding documentation.

All pricing is firm for one year. Extensions are by mutual consent only.



SURPASS CHEMICAL COMPANY, INC.

INDUSTRIAL CHEMICALS WITH TECHNICAL SUPPORT

1254 BROADWAY, ALBANY, NY 12204-0165 - TEL: 518-434-8101 - FAX: 518-434-2798 - customerservice@surpasschemical.com

Dear Town of Carmel Board,

March 29, 2022

Surpass Chemical Company Inc provides water and wastewater chemicals to multiple locations under the Town of Carmel bid C-272. We won that bid starting July 7th, 2021 for one full year with an option to renew. That option is stated to be a unilateral decision by the board. We ask that the board chooses to go back out to bid and not extend pricing.

Due to escalating costs in transportation, raw materials, and regulatory compliance over this last year we are exercising the Saving Clause of the C-272 contract page 6.

'The successful bidder shall not be held responsible for any losses resulting if the fulfillment of the terms of the contract shall be delayed or prevented by wars, acts of God, or for any other acts not within the control of the successful bidder and which by the exercise of reasonable diligence he is unable to prevent.'

Out of the four products we currently supply to your locations raw material costs have gone up from 10-300% depending on the item since the start of the contract period. Continued strain on every aspect of transportation has nearly doubled our cost to get the chemicals used on-site. The continued Russian/Ukraine war has effected fuel costs and threatens to continue to do so for the immediate future. For the ongoing war, unprecedented increases on raw materials and sourcing costs we are exercising the Saving Clause of the contract to not extend pricing past 07/06/22.

Thank you for your business and for making Surpass Chemical your supplier of choice.

Sincerely,

Tim Clayton
Technical Sales Manager