

MICHAEL S. CAZZARI
Town Supervisor

ROBERT F. SCHANIL, JR.
Town Councilman
Deputy Supervisor

STEPHEN J. BARANOWSKI
Town Councilman
FRANK D. LOMBARDI
Town Councilman
SUZANNE MC DONOUGH
Town Councilwoman

TOWN OF CARMEL
TOWN HALL



60 McAlpin Avenue
Mahopac, New York 10541
Tel. (845) 628-1500 • Fax (845) 628-6836
www.ci.carmel.ny.us

ANN SPOFFORD
Town Clerk

KATHLEEN KRAUS
Receiver of Taxes

MICHAEL SIMONE
Superintendent of Highways
Tel. (845) 628-7474

TOWN BOARD VOTING MEETING/WORK SESSION
Wednesday, September 21, 2022 7:00pm

PLEDGE OF ALLEGIANCE - MOMENT OF SILENCE

- **ROLL CALL – ATTENDANCE**
- **Public Comments on Town Related Business (Five (5) Minutes Maximum for Town Residents, Property Owners & Business Owners Only)**

Town Board Voting Meeting:

- **Accept Town Board Minutes August 3 and 17, and September 7, 2022**
1. Res: Authorizing Attendance at Seminar
 2. Res: Authorizing Attendance at Seminar
 3. Res: Waiving the Notice Requirement in Section 64 of the NYS ABC Law with respect to a Liquor License for Dana's Diner, LLC d/b/a Dana's Diner, 565 Route 6, Suite 4, Mahopac, NY
 4. Res: Appointing Counsel – Certiorari Litigation
 5. Res: Acknowledging Emergency Repairs/Services Carmel Water and Sewer Districts
 6. Res: Accepting Proposal for Engineering Services Carmel Water Districts Number 3,4,5,6,8,9,12
 7. Res: Awarding of Bid for the Purchase of Road Salt – Town of Carmel Highway Department
 8. Res: Adopting the 2021 Service Award Annual Reports for Carmel Volunteer Ambulance District #1
 9. Res: Adopting the 2021 Service Award Annual Reports for Carmel Fire Protection District #1
 10. Res: Adopting the 2021 Service Award Annual Reports for Carmel Fire Protection District #2
 11. Res: For Advancement of Government Fund Monies as Temporary Loan from General Fund to Carmel Water District #7
 12. Res: Authorizing Amendment to Contract C-271
 13. Res: Authorizing Highway Superintendent to Proceed with the Purchase of Two Vehicles

14. Res: Authorizing Extension of Contract Carmel Water and Sewer Districts Operation and Maintenance

- **Town Board Comments**
- **Motion to Adjourn Voting Meeting**
- **Motion to Open Work Session**

Town Board Work Session:

1. Michael Carnazza, Building & Codes Enforcer – Consider Request to Attend Tri-County NYSBOC Conference November 15 to 18, 2022 Kingston, NY
 2. Michael Carnazza, Building & Codes Enforcer - Consider Request to Attend NYSERDA Clean Energy Class, November 3, 2022 8:00am - 5:00pm, Newburgh, NY (Free)
 3. Police Chief Anthony Hoffmann – Consider Request to Authorize Tuition Reimbursements per the Town of Carmel PBA Collective Bargaining Agreement, Article XVII “Educational Training”
 4. James Gilchrist, Director of Recreation & Parks – Consider Acknowledgement of Emergency Repairs/Services Boiler Replacement Sycamore Park Recreation Building
- **Motion to Adjourn Work Session Meeting**

RESOLUTION #1

RESOLUTION AUTHORIZING ATTENDANCE AT SEMINAR

RESOLVED that the Town Board of the Town of Carmel hereby authorizes Town of Carmel Fire Inspector Joseph Wilichoski to attend the 2022 Capital District Conference, Albany, New York from October 3 through 5, 2022; and

BE IT FURTHER RESOLVED that the Town Board of the Town of Carmel authorizes payment of reasonable and necessary expenses incurred in connection therewith upon audit.

Resolution

Offered by: _____

Seconded by: _____

<u>Roll Call Vote</u>	<u>YES</u>	<u>NO</u>
Stephen Baranowski	_____	_____
Frank Lombardi	_____	_____
Suzanne McDonough	_____	_____
Robert Schanil	_____	_____
Michael Cazzari	_____	_____

RESOLUTION #2

RESOLUTION AUTHORIZING ATTENDANCE AT SEMINAR

RESOLVED that the Town Board of the Town of Carmel hereby authorizes Glenn Droese, Town Assessor, to attend the 2022 NYS Association of Assessors Fall Conference, Lake George, NY from September 18, 2022 through September 21, 2022; and

BE IT FURTHER RESOLVED that the Town Board of the Town of Carmel authorizes payment of reasonable and necessary expenses incurred in connection therewith upon audit.

Resolution

Offered by: _____

Seconded by: _____

<u>Roll Call Vote</u>	<u>YES</u>	<u>NO</u>
Stephen Baranowski	_____	_____
Frank Lombardi	_____	_____
Suzanne McDonough	_____	_____
Robert Schanil	_____	_____
Michael Cazzari	_____	_____

RESOLUTION #3

RESOLUTION WAIVING THE NOTICE REQUIREMENT IN SECTION 64 OF THE NEW YORK STATE ABC LAW WITH RESPECT TO A LIQUOR LICENSE FOR DANA’S DINER, LLC, D/B/A DANA’S DINER

WHEREAS, the representatives and/or proprietors of Dana’s Diner, 565 Route 6, Suite 4, Mahopac, New York, have advised of the intention to apply for an on-premises liquor license for which thirty days advance notice of such application must be sent to the municipality, and

WHEREAS, the notice required by Article 5 of the ABC Law may be waived by the Town Board, and

WHEREAS, the Town of Carmel Town Board does not intend to comment upon the application referred to herein;

NOW, THEREFORE BE IT RESOLVED, that the Town Board of the Town of Carmel hereby waives the thirty-day notice requirement contained in Article 5 of the Alcoholic and Beverage Control Law, and states that it does not intend to offer any comments regarding said application, for a liquor license at the premises referred to herein; and

BE IT FURTHER RESOLVED that Town Clerk Ann Spofford is hereby authorized to sign a Waiver of Said Notice on behalf of the Town of Carmel.

Resolution

Offered by: _____

Seconded by: _____

<u>Roll Call Vote</u>	<u>YES</u>	<u>NO</u>
Stephen Baranowski	_____	_____
Frank Lombardi	_____	_____
Suzanne McDonough	_____	_____
Robert Schanil	_____	_____
Michael Cazzari	_____	_____

RESOLUTION #4

**RESOLUTION APPOINTING COUNSEL
CERTIORARI LITIGATION**

RESOLVED, that the Town Board of the Town of Carmel, hereby appoints John B. Cherico, 312 Battle Avenue, White Plains, NY as counsel for the Town of Carmel in the matter known as “1875 Route 6, LLC v. The Town of Carmel” and pending in Putnam County Supreme Court under index number 500796/2022; and

BE IT FURTHER RESOLVED that said services are hereby authorized at a rate of \$300.00 per hour.

Resolution

Offered by: _____

Seconded by: _____

<u>Roll Call Vote</u>	<u>YES</u>	NO
Stephen Baranowski	___	___
Frank Lombardi	___	___
Suzanne McDonough	___	___
Robert Schanil	___	___
Michael Cazzari	___	___

RESOLUTION #5

**RESOLUTION ACKNOWLEDGING EMERGENCY REPAIRS/SERVICES CARMEL
WATER AND SEWER DISTRICTS**

RESOLVED, the Town Board of the Town of Carmel, acting as Commissioners of the various water and sewer districts of the Town of Carmel, upon the recommendation of Town Engineer, Richard J. Franzetti, PE, hereby acknowledges the emergency performance of water and sewer district collection system/distribution system and treatment facilities repairs as fully detailed in the invoices attached hereto and made a part thereof.

Resolution

Offered by: _____

Seconded by: _____

<u>Roll Call Vote</u>	<u>YES</u>	<u>NO</u>
Stephen Baranowski	_____	_____
Frank Lombardi	_____	_____
Suzanne McDonough	_____	_____
Robert Schanil	_____	_____
Michael Cazzari	_____	_____

TOWN OF CARMEL

60 MCALPIN AVE
MAHOPAC, NY 10541
PHONE # (845) 628-1500 FAX #

Check Number:
Voucher Number: 47526
Batch Number: DE
PO Number: 31740
Pay Due: 08/31/2022
Check ID: 00019
Check Date:
Creation Date: 08/29/2022
Invoice Number: 102273
Page: 1 of 1

Voucher

Vendor: 0000000476
BEE & JAY CORP.
PLUMBING AND HEATING
719 ROUTE 6
MAHOPAC, NY 10541

CONTRACT # BOARD ACKNOWLEDGEMENT
FED ID/SS: 13-2536375

Ship To:
TOWN OF CARMEL
ENGINEERING DEPT.
60 MCALPIN AVENUE
MAHOPAC, NY 10541
Phone # (845) 628-1500

Bill To:
TOWN OF CARMEL
ENGINEERING DEPT.
60 MCALPIN AVENUE
MAHOPAC, NY 10541

Description: CWD3, EMERGENCY SPRING ST STATION PUMP REPLACEMENT ***INSURANCE

Total \$10,815.40

Date	Qty.	Unit	Description	Unit Price	Amount
08/08/2022			CWD3, EMERGENCY SPRING ST STATION PUMP REPLACEMENT ***INSURANCE		10,815.40
			603.8310.0047 (Balance Available: -7,491.41) (CWD #3-LAKE SECOR...EMERGENCY REPAIRS)		
			Total:		\$10,815.40

*****APPROVAL FOR PAYMENT***** The claim is approved and ordered paid from the appropriations indicated above.

Comptroller *Maylan Maxwell* Date

Town Comptroller

TOWN OF CARMEL

60 MCALPIN AVE
MAHOPAC, NY 10541

PO Number : 31740
Date : 08/25/2022
Page: 1 of 1

Purchase Order

Vendor : 0000000476
BEE & JAY CORP.
PLUMBING AND HEATING
719 ROUTE 6
MAHOPAC, NY 10541

Ship To:
TOWN OF CARMEL
ENGINEERING DEPT.
60 MCALPIN AVENUE
MAHOPAC, NY 10541
Phone # (845) 628-1500

Bill To:
TOWN OF CARMEL
ENGINEERING DEPT.
60 MCALPIN AVENUE
MAHOPAC, NY 10541

CONTRACT # BOARD ACKNOWLEDGEMENT

Description: CWD3, EMERGENCY SPRING ST STATION PUMP REPLACEMENT ***INSURANCE

Qty.	Unit	Description	Unit Price	Amount
		CWD3, EMERGENCY SPRING ST STATION PUMP REPLACEMENT ***INSURANCE 603.8310.0047 (CWD #3-LAKE SECOR...EMERGENCY REPAIRS)		10,815.40
			Total:	\$10,815.40

Ordered By: DONNA Req. Date: 08/23/2022 Req. No: 28002 Approved By/Date:

Authorized Official

Date



INVOICE

P.O. Box 78 - 719 Route 6 - Mahopac, NY 10541

p: 845.628.3924 f: 845.628.4062

e: service@beeandjay.com

DATE	INVOICE #
8/8/2022	102273

www.BEEANDJAY.com

BILL TO:

Town Of Carmel- CWD 3
Engineering Dept.
60 McAlpin Ave.
Mahopac, NY 10541

SERVICE LOCATION:

Town Of Carmel- CWD 3
Spring Street Station
Mahopac, NY

PROFESSIONAL SERVICE 58 YEARS 1964-2022

Master Plumbers Lic.#s W.C. 556 P.C. 363

CUSTOMER #	TERMS	MECHANIC	SERVICE DATE	WORK ORDER #	
845 628 1500	Payment Due Upon Rec	EK	8/1/2022	62331	
ITEM	QTY/HRS	DESCRIPTION		RATE	AMOUNT
Description		CWD #3 Spring Street Station - well #3 pump and motor burnt out due to lightening damage. Pulled and replaced with all related equipment and restored on line.			
Labor TOC Tech	8	1- Tech Plb		185.00	1,480.00
Labor TOC Lab...	8	1-Laborer		140.00	1,120.00
Boom Truck		Boom Truck		1,000.00	1,000.00
Material		1- 5 hp 230 v 3 phase Motor		2,340.00	2,340.00
Material		1- 25GS350 Pump End		2,347.00	2,347.00
Material		3- Large Heat Shrinks		38.85	38.85
Material		10- Rolls Tape		50.00	50.00
Material		2- Torque Arrestor		70.00	70.00
Material		400 feet 8-4 Sub Cable		2,350.00	2,350.00
Material		1- 1-1/4x4 Brass Nipple		19.55	19.55

** Invoices not paid when due will be subjected to a finance charge of 1.5% per month

Total Due \$10,815.40

WE ACCEPT ALL MAJOR CREDIT CARDS !!

CARD TYPE: VISA MASTERCARD AMERICAN EXPRESS DISCOVER DINER'S CLUB OTHER _____

CARDHOLDER/NAME: _____ SIGNATURE: _____

CARD# _____ EXP. DATE: _____ CID # _____

EMAIL: _____

EXHIBIT "B"

**Emergency Justification Form
Town of Carmel Procurement Policy**

Procurement Policy, Section VI: Emergency Procurement

Subdivision (4) of General Municipal Law §103 sets forth an exception to purchasing and bidding requirements for emergency situations

Department: Engineering

Vendor name: Bee and Jay Plumbing

Nature of emergency: Emergency Pump Replacement

Estimated cost: See attached

There are three basic statutory criteria to be met in order to fall within the emergency purchase exception. State the basis for identifying an emergency purchase or service, check any that apply:

- The situation arose out of an accident or unforeseen occurrence or condition.
- Public buildings, public property, or the life, health, safety or property of the political sub-division's residents were affected.
- The situation required immediate action, which could not await competitive bidding.
- The emergency purchases or services exceeded **\$10,000** and will be submitted to the Town Board for presentation at a Town Board Meeting to acknowledge said emergency. A Town Board Resolution should be passed acknowledging the same.
- Other (provide explanation):

Purchasing Agent's signature for approval: _____



Department Head's signature for approval: _____

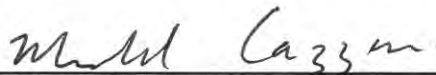

U.S. Department of Labor
Wage and Hour Division

PAYROLL
(For Contractor's Optional Use; See Instructions at www.dol.gov/whd/forms/wh347instr.htm)



Persons are not required to respond to the collection of information unless it displays a currently valid OMB control number.

NAME OF CONTRACTOR OR SUBCONTRACTOR **BRE & JAY PLS-ITG Corp.** ADDRESS **719 RT. 6 MANHATTAN, N.Y. 10541**

PAYROLL NO. FOR WEEK ENDING **8/6/22** PROJECT AND LOCATION **Tour of Cherry** PROJECT OR CONTRACT NO. **Unit 3 + Unit 4**

OMB No.: 1235-0008
Expires: 04/30/2021

(1) NAME AND INDIVIDUAL IDENTIFYING NUMBER (e.g., LAST FOUR DIGITS OF SOCIAL SECURITY NUMBER) OF WORKER	(2) NO. OF WITHHOLDING EXEMPTIONS	(3) WORK CLASSIFICATION	(4) DAY AND DATE							(5) TOTAL HOURS	(6) RATE OF PAY	(7) GROSS AMOUNT EARNED	(8) DEDUCTIONS				(9) NET WAGES PAID FOR WEEK		
			OT	DR	SA	SH	FR	SA	SH				FR	SA	SH	FR		FICA	WITH-HOLDING TAX
Joseph Scollan [REDACTED]		PLS meat								3	3	56.46	220.24						
Eugene Kugler [REDACTED]		PLS meat								8	8	56.94	557.96						
Dawn Ferris [REDACTED]		PLS meat								3	3	56.96	220.24						
Nicole Stenevick [REDACTED]		Cabin								8	8	46.53	518.82						

While completion of Form WH-347 is optional, it is mandatory for covered contractors and subcontractors performing work on Federally financed or assisted construction contracts to respond to the information collection contained in 29 C.F.R. §§ 3.3, 5.5(a). The Copeland Act (40 U.S.C. § 3145) contractors and subcontractors performing work on Federally financed or assisted construction contracts to "furnish weekly a statement with respect to the wages paid each employee during the preceding week." U.S. Department of Labor (DOL) regulations at 29 C.F.R. § 5.5(e)(3)(ii) require contractors to submit weekly a copy of all payrolls to the Federal agency contracting for or financing the construction project, accompanied by a signed "Statement of Compliance" indicating that the payrolls are correct and complete and that each laborer or mechanic has been paid not less than the proper Davis-Bacon prevailing wage rate for the work performed. DOL and federal contracting agencies receiving this information review the information to determine that employees have received legally required wages and fringe benefits.

Public Burden Statement

We estimate that it will take an average of 55 minutes to complete this collection, including time for reviewing instructions, searching existing data sources, gathering and maintaining the data needed, and completing and reviewing the collection of information. If you have any comments regarding these estimates or any other aspect of this collection, including suggestions for reducing this burden, send them to the Administrator, Wage and Hour Division, U.S. Department of Labor, Room S3502, 200 Constitution Avenue, N.W., Washington, D.C. 20210

RESOLUTION #6
RESOLUTION ACCEPTING PROPOSAL FOR ENGINEERING
SERVICES CARMEL WATER DISTRICTS NUMBER 3,4,5,6,8,9 & 12

WHEREAS, the Town Board of the Town of Carmel, acting as Commissioners of Carmel Water Districts #s 3,4,5,6,8,9 and 12 and pursuant to the direction of the Putnam County Health Department previously authorized an investigation into the presence of PFOA/PFOS compounds within Water Districts #s 3,4,5,6,8,9 and 12, their boundaries, water treatment plant facilities and/or distributions systems; and

NOW THEREFORE BE IT RESOLVED, that the Town Board of the Town of Carmel, upon the recommendation of Town Engineer Richard J. Franzetti, P.E. and acting as Commissioners of Carmel Water Districts #s 3,4,5,6,8,9 and 12, hereby accepts the proposal of J. Robert Folchetti & Associates, LLC, Brewster, NY to develop and provide the best available treatment plan for Carmel Water Districts #s 3,4,5,6,8,9 and 12 to provide safe drinking water to the district residents in accordance with the terms of the proposal dated August 12, 2022 as attached hereto and made a part hereof at a cost not to exceed \$17,500 per district; and

BE IT FURTHER RESOLVED that Town Supervisor Michael Cazzari is hereby authorized to execute any and all documentation reasonably necessary to effectuate the authorized hereunder; and

BE IT FURTHER RESOLVED that Town Comptroller MaryAnn Maxwell is hereby authorized to make any and all necessary budget modifications required in connection with this authorization

Resolution

Offered by: _____

Seconded by: _____

<u>Roll Call Vote</u>	<u>YES</u>	<u>NO</u>
Stephen Baranowski	_____	_____
Frank Lombardi	_____	_____
Suzanne McDonough	_____	_____
Robert Schanil	_____	_____
Michael Cazzari	_____	_____

August 29, 2022

Town of Carmel Town Board
Town of Carmel
60 McAlpin Avenue
Mahopac, New York 10541
Attn: Hon. Michael Cazzari, Supervisor

**RE: PROPOSAL FOR ENGINEERING SERVICES
CARMEL WATER DISTRICTS 3, 4, 5, 6, 8, 9 and 12
PFOA/PFOS TREATMENT INVESTIGATION**

Dear Supervisor Cazzari:

We are pleased to submit our proposal for professional engineering services required for the referenced investigation. JRFA's understanding of the project is as follows:

PFOA/PFOS are man-made chemicals that, due to their oil and water repelling properties, have been manufactured and used around the world since the 1940s. Routine PFOA/PFAS samples have been collected in all Carmel Water Districts as directed by the Putnam County Department of Health. The results in Districts 3, 4, 5, 6, 9, and 12 exceed the NYS Maximum Contaminant Level (MCL) of 10 parts per trillion for both chemicals, rendering these Districts non-compliant to the New York State Sanitary Code. The Putnam County Department of Health has directed PFOA/PFOS treatment at these facilities. NYSDOH cites Granular Activated Carbon (GAC) as the Best Available Treatment for PFOA/PFOS. Before committing to individual treatment plants at each District, JRFA recommends the evaluation of alternative methods to provide safe drinking water to the District residents. These alternatives should include:

- Operational changes at the facilities;
- Drilling additional well or wells;
- Alternative sources of supply;
- District consolidation;
- Treatment options;
- A combination of alternatives.

The objective is to find the most cost-effective method of providing safe drinking water across the referenced Districts.

While all Districts have conducted sampling as discussed above, Carmel Water District 8 has not experienced any exceedance of the MCL's to date. However, due to the presence of a State Superfund Site in downtown Mahopac, the NYSDOH has sampled private wells around the hamlet. To date over 100 hundred of these wells have been sampled; with one exception, all have tested positive for PFOA/PFOS. The NYSDOH has provided bottled water to these residents and has installed point of entry treatment (POET) systems at approximately half of them. This proposal will consider the requirements for an expansion of the existing Carmel Water District 8 to address the contamination of private wells for these residents.

31 Sodom Road
Brewster, New York 10509
845-363-1560
845-582-0485 FAX
www.jrfa.com

For your convenience, we have divided the proposal into five sections as follows:

SECTION 1 - PROPOSED SCOPE OF WORK
SECTION 2 - WORK BY OTHERS
SECTION 3 - ESTIMATED COSTS AND SCHEDULE
SECTION 4 - PAYMENT SCHEDULE
SECTION 5 - ADDITIONAL SERVICES

SECTION 1 – PROPOSED SCOPE OF WORK

TASK 1.0 The general engineering tasks necessary to complete this project for Districts 3, 4, 5, 6, 9, and 12, in general order of occurrence, are as follows:

- 1.1 Evaluate sampling data
- 1.2 Develop current sampling data (daily for 2 weeks) for all water quality parameters germane to treatment alternatives:
 - 1.2.1 PFOS/PFAS/1,4 Dioxane
 - 1.2.2 Total Suspended Solids
 - 1.2.3 Iron, Manganese and Calcium
 - 1.2.4 Total Organic Carbon
 - 1.2.5 Radon
 - 1.2.6 pH
- 1.3 Document and Evaluate Current Treatment Processes and Facilities
- 1.4 Well Data
 - 1.4.1 History and current yields
 - 1.4.2 Well Field size and location
 - 1.4.3 Potential for location of additional well(s)
- 1.5 District Demand
 - 1.5.1 Average Day
 - 1.5.2 Maximum Day
- 1.6 Alternative Evaluation
 - 1.6.1 Operational changes
 - 1.6.2 Potential for additional well(s)
 - 1.6.3 Alternative sources of supply
 - 1.6.4 Consolidation with other Districts
 - 1.6.4.1 Proximity and Routing
 - 1.6.4.2 Combined Supply
 - 1.6.4.3 Combined Demand
 - 1.6.4.4 Combined Water Quality
 - 1.6.5 Treatment
 - 1.6.5.1 Existing processes
 - 1.6.5.2 Raw Water Quality
 - 1.6.5.3 Granular Activated Carbon/Ion Exchange/Reverse Osmosis
 - 1.6.5.3.1 Unit sizing
 - 1.6.5.3.2 Pretreatment Requirements
 - 1.6.5.3.3 Impact on Existing Equipment
 - 1.6.5.3.4 Facilities Required
 - 1.6.5.3.5 Area Available
 - 1.6.5.4 Pilot Testing Criteria

1.6.6 Combination of Alternatives

- 1.7 Cost Estimate for Alternatives Evaluated under Task 1.6
- 1.8 Develop 10 State Standard Compliant Engineering Report, including Recommended Project Selection for each District
- 1.9 Coordination with Putnam County Department of Health

TASK 2.0 The general engineering tasks necessary to complete this project for District 8, in general order of occurrence, are as follows:

- 2.1 Evaluate NYSDOH sampling data
- 2.2 Document and Evaluate Current Plant
 - 2.2.1 Treatment Processes
 - 2.2.2 Facilities
 - 2.2.3 Intake Capacity
 - 2.2.4 Storage
 - 2.2.5 Land Availability
- 2.3 Existing District Data
 - 2.3.1 History, Current Yield, and Safe Yield
 - 2.3.2 Average Day Demand
 - 2.3.3 Maximum Day Demand
- 2.4 Expanded District Data
 - 2.4.1 Proposed District Service Area
 - 2.4.2 Proposed District Use by Type
 - 2.4.2.1 Residential
 - 2.4.2.2 Commercial
 - 2.4.2.3 Institutional
 - 2.4.3 Average Day Demand
 - 2.4.4 Maximum Day Demand
- 2.5 Alternative Evaluation
 - 2.5.1 Plant Expansion
 - 2.5.2 Intake Requirements
 - 2.5.3 Storage Requirements
 - 2.5.4 Distribution
 - 2.5.4.1 Pipe Routing
 - 2.5.4.2 Booster Pumps
 - 2.5.5 Land Acquisition
- 2.6 Cost Estimate
- 2.7 Develop 10 State Standard Compliant Engineering Report
- 2.8 Coordination with NYS and Putnam County Departments of Health

SECTION 2 - WORK BY OTHERS

JRFA's scope of work, as specified in this proposal, is limited to the Work outlined in Section 1 above, with additional work to be performed upon request. We propose that samples be collected and delivered to the lab by the Operators and billed to JRFA. JRFA will provide assistance to the Town in the procurement and coordination of other additional services, as required. Where JRFA retains sub-consultants on behalf of the OWNER they will be billed at cost.

SECTION 3 - ESTIMATED COSTS AND SCHEDULE

JRFA can commence work immediately on this project.

It is estimated that Tasks 1.1 through 1.9 can be completed within 210 days of Notice to Proceed. Since the scope of work is identical for each District and is not based on District size, we offer a flat rate of \$17,500.00 per District, excluding costs for sample collection and analysis as discussed above. We will pass these on as direct costs without a handling fee.

It is estimated that Tasks 2.1 through 2.8 can be completed within 240 days of Notice to Proceed. The estimated cost for Tasks 2.1 through 2.8 is \$42,000.00.

Any costs for additional services as outlined below will be billed under our Hourly Rate Schedule (see attached). These costs will not be exceeded without prior authorization of the Owner.

SECTION 4 - PAYMENT SCHEDULE

We will bill you monthly as the work progresses; payment is expected within 30-days of receipt of our invoices. We reserve the right to discontinue or suspend work if outstanding invoices exceed 45 days.

The following costs will constitute a separate item for reimbursement:

- Project connected traveling expenses;
- Printing, reproduction, legal, laboratory, shipping and other costs not attributable to general overhead;
- All agency fees to be paid by Owner.

SECTION 5 - ADDITIONAL SERVICES

Any work not identified herein is specifically excluded. JRFA will provide the Owner with an estimated cost for completing any additional services tasks prior to executing the work.

We are available to discuss any aspect of this proposal with you at your convenience. If this proposal is satisfactory please execute and return one copy.

Very truly yours,

ENGINEER

 29 AUG '22
John E. Folchetti, P.E. Date

**OWNER or
AUTHORIZED SIGNATURE**

Signature Date

J. ROBERT FOLCHETTI & ASSOCIATES, L.L.C.
ENGINEERING RATES

<u>CLASSIFICATION</u>	<u>\$ PER HOUR</u>
Principal	\$160.00 - \$210.00
Project Manager	\$150.00 - \$200.00
Project Engineer / Geologist	\$120.00 - \$150.00
Engineer / Designer	\$ 95.00 - \$130.00
Engineer / Inspector	\$ 70.00 - \$100.00
Other Technical Personnel	\$ 75.00 - \$100.00

REIMBURSABLES

- Travel, Subsistence and Incidentals
- Use of motor vehicles on a mileage basis, consistent with IRS allowances
- Reproduction costs
- Postage and shipping for project related materials
- Rental charges for equipment, including equipment owned by the Engineer
- Cost of acquiring any other materials or services specifically for and applicable to this project. This includes any special requests for accounting backup or support.
- Subconsultants, as required, will be billed at cost plus 5%.

These rates are guaranteed through December 31, 2022.

RESOLUTION #7

RESOLUTION AUTHORIZING AWARDING OF BID FOR THE PURCHASE OF ROAD SALT – TOWN OF CARMEL HIGHWAY DEPARTMENT

RESOLVED THAT the Town Board of the Town of Carmel, upon the recommendation of Town of Carmel Highway Superintendent Michael Simone, hereby authorizes the awarding of bid for the purchase of road salt for the period of September 1, 2022 through August 31, 2023 from Morton Salt, Inc., under New York State Office of General Services Group#01800 Award # 23248 Contract No. PC 69477 at the unit prices set forth therein.

Resolution

Offered by: _____

Seconded by: _____

<u>Roll Call Vote</u>	<u>YES</u>	NO
Stephen Baranowski	___	___
Frank Lombardi	___	___
Suzanne McDonough	___	___
Robert Schanil	___	___
Michael Cazzari	___	___

RESOLUTION #8

**RESOLUTION ADOPTING THE 2021 SERVICE AWARD
ANNUAL REPORTS FOR CARMEL AMBULANCE DISTRICT NO. 1**

RESOLVED that the Town Board of the Town of Carmel, acting as Commissioners of Carmel Ambulance District No.1, hereby accepts the 2021 Length of Service Award Program Annual Report for Carmel Ambulance District No. 1 as prepared by Penflex, Inc., a copy of which is on file in the Office of the Town Supervisor.

Resolution

Offered by: _____

Seconded by: _____

<u>Roll Call Vote</u>	<u>YES</u>	<u>NO</u>
Stephen Baranowski	___	___
Frank Lombardi	___	___
Suzanne McDonough	___	___
Robert Schanil	___	___
Michael Cazzari	___	___

RESOLUTION #9

**RESOLUTION ADOPTING THE 2021 SERVICE AWARD ANNUAL REPORTS FOR
CARMEL FIRE PROTECTION DISTRICT NO. 1**

RESOLVED that the Town Board of the Town of Carmel, acting as Commissioners of Carmel Fire Protection District No.1, hereby accepts the 2021 Length of Service Award Program Annual Report for Carmel Fire Protection District No. 1 as prepared by Penflex, Inc., a copy of which is on file in the Office of the Town Supervisor.

Resolution

Offered by: _____

Seconded by: _____

<u>Roll Call Vote</u>	<u>YES</u>	NO
Stephen Baranowski	___	___
Frank Lombardi	___	___
Suzanne McDonough	___	___
Robert Schanil	___	___
Michael Cazzari	___	___

RESOLUTION #10

**RESOLUTION ADOPTING THE 2021 SERVICE AWARD ANNUAL REPORTS FOR
CARMEL FIRE PROTECTION DISTRICT NO. 2**

RESOLVED that the Town Board of the Town of Carmel, acting as Commissioners of Carmel Fire Protection District No. 2, hereby accepts the 2021 Length of Service Award Program Annual Report for Carmel Fire Protection District No. 2 as prepared by Penflex, Inc., a copy of which is on file in the Office of the Town Supervisor.

Resolution

Offered by: _____

Seconded by: _____

<u>Roll Call Vote</u>	<u>YES</u>	NO
Stephen Baranowski	___	___
Frank Lombardi	___	___
Suzanne McDonough	___	___
Robert Schanil	___	___
Michael Cazzari	___	___

RESOLUTION #11

RESOLUTION FOR ADVANCEMENT OF GOVERNMENT FUND MONIES AS TEMPORARY LOAN FROM GENERAL FUND TO CARMEL WATER DISTRICT #7

RESOLVED, that the Town Board of the Town of Carmel, pursuant to Town Law §209-b, hereby authorizes the Temporary Advancement of Cash from the General Fund to Carmel Water District #7 at a maximum amount not to exceed \$100,000, to be repaid with the periodic interest rate when revenue sources or debt proceeds are received.

Resolution

Offered by: _____

Seconded by: _____

<u>Roll Call Vote</u>	<u>YES</u>	NO
Stephen Baranowski	___	___
Frank Lombardi	___	___
Suzanne McDonough	___	___
Robert Schanil	___	___
Michael Cazzari	___	___

RESOLUTION #12

RESOLUTION AUTHORIZING AMENDMENT TO CONTRACT C-271

RESOLVED, that the Town Board of the Town of Carmel, acting as Commissioners of the various sewer districts within the Town of Carmel, hereby authorizes amendment of the existing sludge hauling contract with Wind River Environmental, Vernon NJ, for sludge hauling services within Carmel Sewer Districts #2, #4, #5, #6, and #7; and

BE IT FURTHER RESOLVED that said amendment shall be effective September 1, 2022 through and including conclusion of the contract period of June 30, 2023 and shall be a price per gallon of \$0.157 from September 1, 2022 through September 30, 2022; \$0.167 from October 1, 2022 through October 31, 2022; and \$0.177 from November 1, 2022 through and including June 30, 2023; and

BE IT FURTHER RESOLVED that Town Supervisor Michael S. Cazzari is hereby authorized to sign any and all documentation necessary to effect the amendment authorized upon the terms set forth herein.

Resolution

Offered by: _____

Seconded by: _____

<u>Roll Call Vote</u>	<u>YES</u>	NO
Stephen Baranowski	___	___
Frank Lombardi	___	___
Suzanne McDonough	___	___
Robert Schanil	___	___
Michael Cazzari	___	___

RESOLUTION #13

**RESOLUTION AUTHORIZING HIGHWAY
SUPERINTENDENT TO PROCEED WITH THE PURCHASE
OF TWO VEHICLES**

RESOLVED that the Town Board of the Town of Carmel hereby authorizes Town of Carmel Highway Superintendent Michael Simone to proceed to purchase two (2) 2024 International 4x4 HV507 Cab & Chassis together with Tenco Dump Body, Plow and Sander from Allegiance Trucks, Hudson, NY, at an aggregate unit cost not to exceed \$303,742.38 under Onondaga County #8996 Statewide Piggy Back Bid pursuant to General Municipal Law §103(16); and

BE IT FURTHER RESOLVED that Town Supervisor Michael Cazzari is hereby authorized to sign all necessary documents to purchase said vehicles from Allegiance Trucks in accordance with their bid/contract quotations dated August 31, 2022; and

BE IT FURTHER RESOLVED, that Town Comptroller Mary Ann Maxwell is hereby authorized to make any and all necessary budget revisions to effect the aforesaid purchase transactions authorized herein.

Resolution

Offered by: _____

Seconded by: _____

<u>Roll Call Vote</u>	<u>YES</u>	NO
Stephen Baranowski	_____	_____
Frank Lombardi	_____	_____
Suzanne McDonough	_____	_____
Robert Schanil	_____	_____
Michael Cazzari	_____	_____

RESOLUTION #14

**RESOLUTION AUTHORIZING EXTENSION OF CONTRACT
CARMEL WATER AND SEWER DISTRICT OPERATIONS
AND MAINTENANCE**

WHEREAS the Town Board of the Town of Carmel, acting as Commissioners of the various water districts of the Town of Carmel, has previously entered into a contract with Inframark, LLC for the operation and maintenance of Carmel Sewer Districts #1, #2, #3, #4, #5, #6, #7, #8 and Carmel Water Districts #2, #3 and #12 dated March 5, 2018;

NOW THEREFORE BE IT RESOLVED, that the Town Board of the Town of Carmel, acting as Commissioners of the aforementioned sewer and water districts hereby authorizes the extension of the referenced contract for a period of five (5) years commencing January 1, 2023 through and including December 31, 2027, said extension to be in form as attached hereto and made a part hereof; and

BE IT FURTHER RESOLVED, that Town Supervisor Michael Cazzari is hereby authorized to sign the aforesaid contract amendment.

Resolution

Offered by: _____

Seconded by: _____

<u>Roll Call Vote</u>	<u>YES</u>	NO
Stephen Baranowski	_____	_____
Frank Lombardi	_____	_____
Suzanne McDonough	_____	_____
Robert Schanil	_____	_____
Michael Cazzari	_____	_____



PREPARED FOR:

Mr. Michael Cazzari
Town Supervisor
Town of Carmel
60 McAlpin Avenue
Carmel, NY 10541



September 20, 2022

Mr. Michael Cazzari
Town Supervisor, Town of Carmel
60 McAlpin Avenue, Carmel, NY 10541

Mr. Cazzari:

Inframark, LLC (Inframark) is proud of our work for the Town of Carmel (Town) and the partnership we have forged with the Town — a partnership we most certainly want to continue. For over twenty-six years, we have teamed with the Town in successfully managing the Town’s six sewer districts, three water districts, twenty-two primary pump stations, and 115 on-lot pump stations. Our unique and detailed knowledge of your facilities allows us to provide unmatched services.

Our people are and always will be our greatest asset!

Inframark provides years of experience in the day-to-day operations of Carmel’s facilities. We have an extensive retention program (training & development, merit increases, incentive programs) to help ensure we retain our people for the Town.



Inframark also provides at no additional cost to the Town a support staff for the management of water and wastewater services. We offer a knowledgeable team of administrators, project managers, engineers, and compliance & safety officers that work together and trade expertise to assure project success for Carmel.

Safety and regulatory compliance are Inframark’s top priorities; there is no alternative approach or compromise when it comes to ensuring the safe and compliant operation of your facilities for our operations staff and all who visit our operations. Inframark has over seven years without a recordable or lost time incident with the Town.

Our partnership is foundational to our combined success. Nationally, we achieve 99.9% compliance at all our facilities. Inframark strives every day in Carmel to achieve exact national compliance. We have built robust process control plans laying the groundwork for consistent environmental compliance performance. The data collected is stored in the Inframark Hach WIMS Data Management System that is readily accessible to the Town. This service is provided as part of our partnership with the Town.

YEAR	%COMPLIANCE
2016	99.9
2017	100.0
2018	99.8
2019	99.7
2020	99.8
2021	99.4
YTD May 2022	99.4



In the past, Inframark has implemented the following performance tools for the Town to achieve maximum standards and monetary savings.

- **Asset Management Program** - Includes an industry “best in class” CMMS - computerized maintenance management system that captures the history of all the Town’s assets; this includes maintenance and repairs for all assets. We have implemented a data-driven proactive maintenance program to extend the useful life of your assets and reduce unexpected failures. This includes tracking warranties, determining predictive and preventive maintenance tasks, and generating work requests and work orders. CMMS is a tool that helps create annual budgets and capital planning by measuring asset conditions and expenses. The mechanics have also transitioned to tablets to capture accurate time information and improve the accuracy of the work order data.
- **Key Performance Indicators** - Each plant has tailored process control plans, SOPs, and key process indicators to give the operators a detailed set of instructions for consistent operations.
- **WIMS operational daily logs for each Facility** - All operations data is input daily and tracked to ensure adherence to the process control plan. Information is also used for regulatory reporting.



Value Added Services Provided by Inframark

Water Main Re-Lining Project - Worked closely with the outside engineering firm and the Town over system layout and functionality. Assisted in identifying issue areas within the distribution system to redirect funds/necessary repairs once it was discovered some sections of main did not require lining. Overall, it helped improve the Water District #2 distribution system by redirecting work to key areas not initially scoped in the re-lining project resulting in a more reliable distribution system.

Water Main / Service Locating - Located and identified water mains alongside each re-lining contractor. They assisted in identifying types of pipelines underground not previously noted in district maps which contributed to whether they were lined.



Tank Rehabilitation / Replacement Project - Worked closely with the outside engineering firm, contractors, and the Town to ensure public safety was not at risk. Stayed multiple times off hours to monitor tank filling operations. Shut down said operations once it was deemed unsafe. We had numerous conference calls with Weston and Sampson to agree on a new safe plan for refilling the Water District #3 storage tank. Once the tank was filled, we worked with the Putnam Department of Health to take the necessary coliform samples to restore the tank to regular operation. Since this was the first District to have this work performed, all information and pitfalls found were shared with Bee and Jay to alleviate issues they may encounter throughout their rehabilitation projects and to avoid any unnecessary burdens on district residents.

Emergency Call Outs - Responded to emergency call-outs from residents regarding leaks/pressure issues throughout this rehabilitation process. At the Town's request, we installed the temporary water connection to 3 Crosshill Road to alleviate tensions with the resident. Previous attempts from another contractor led to a leak inside the resident's home, and it was decided Inframark would be the best option to ensure no further issues occurred. Tensions with the resident were smoothed over, and the temporary service served them throughout the filling process to ensure they had safe drinking water supplied to their home.

Carmel Water District #2 Diatomaceous Earth Procurement - Procured five pallets of diatomaceous earth from Northern Westchester Joint Water Works at no cost to the town of Carmel. Worked with Putnam County DOH for approval of using this Diatomaceous Earth. Inframark ran test trials at Water District #2 and reported to Putnam County DOH to ensure all safety concerns had been met. We are actively transporting the Diatomaceous Earth from Cortland Manner one pallet at a time with Inframark vehicles and personnel. This service was a \$5,000 savings for the Town.

Headworks improvements at Sewer District #2 - Assisted Town Engineer with research on equipment and design along with specification review:

- Ongoing Repairs and Replacement of Equipment at all Facilities
- Flow Testing as Requested of Fire Hydrants
- Repairs at the Town Hall Sewer Pump Station
- Research help with PFOA issues



ORGANIZATIONAL CHART

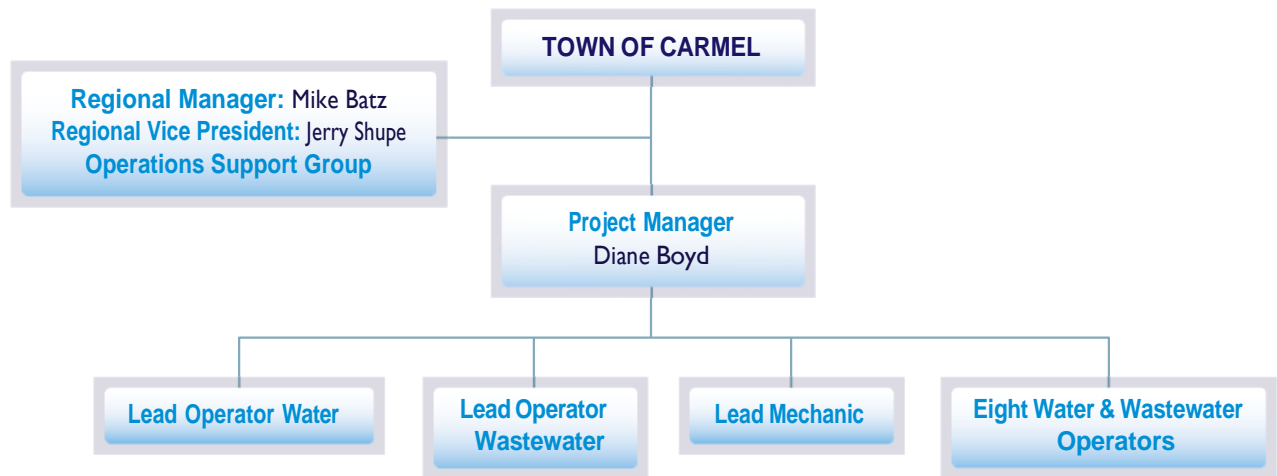



Proposed Pricing

Inframark requests an agreement that shall commence on January 1, 2023 and remain in full force and effect for five years. The agreement shall be automatically renewed for three successive three-year periods commencing on January 1, 2028.

2023		Increase	AVG	AVG % Increase									
QTR 2.5%	\$ 1,609,179.06	\$ 96,909.46	\$134,098.26	6%									
Jan	Feb	Mar	Apr	May	Jun	Jul	Aug	Sep	Oct	Nov	Dec	Total	
\$ 129,173.03	\$ 129,173.03	\$ 129,173.03	\$ 132,402.35	\$ 132,402.35	\$ 132,402.35	\$ 135,712.41	\$ 135,712.41	\$ 135,712.41	\$ 139,105.22	\$ 139,105.22	\$ 139,105.22	\$1,609,179.06	QTR 2.5%
2024		Increase	AVG	AVG % Increase									
Price Increase on Oct Increase	\$ 1,752,725.82	\$ 83,463.13	\$146,060.49	5%									
Jan	Feb	Mar	Apr	May	Jun	Jul	Aug	Sep	Oct	Nov	Dec	Total	
\$ 146,060.49	\$ 146,060.49	\$ 146,060.49	\$ 146,060.49	\$ 146,060.49	\$ 146,060.49	\$ 146,060.49	\$ 146,060.49	\$ 146,060.49	\$ 146,060.49	\$ 146,060.49	\$ 146,060.49	\$ 1,752,725.82	Annual 5%
2025 CPI Max 5%													

Annual Price Adjustment

For each calendar year starting on January 1, 2025, the parties shall negotiate an increase to the Operator's Base Compensation for each subsequent Calendar Year in good faith. If the parties cannot agree to an increase in the Base Compensation by the start of each Calendar Year, the Operator's Base Compensation will be automatically increased by a maximum of 5% CPI increase. The prevailing wage rates, if applicable, will automatically increase per State of New York Labor Laws.

If Inframark is required to pay prevailing wages when performing the services, the Town is to pay Inframark for the prevailing wage rates plus a 10% administrative fee; however, there will be no percentage markup adjustments throughout the length of the agreement. No additional labor cost will be charged to the Town for installation of provided equipment that would be installed by Inframark staff employees (pump replacement, communitor grinder, etc.)



The forecasted prevailing wage costs in the first year of this agreement based on the applicable New York State prevailing wage rates are as follows:

WORK TYPE	2023 FORECAST HOURS	2023 RATE	2023 FORECAST
Millright-Putnam County	1385	128.34	\$177,750.90
Operating Engineering Survey	181	76.39	\$13,826.59
Total:	1566.00		\$191,577.49

*****The following will allow for the prevailing wage rates to drop significantly.** For any prevailing wage work performed during regular business hours as per State of New York Labor Laws, all Inframark contract assigned employees will have a \$25.00/hour reduction from their applicable prevailing wage rate to account for their compensation under the Base Compensation. Should prevailing wage work be performed during nights, weekends, or holidays, the above rates may differ per State of New York Labor Laws. Inframark will make every reasonable effort to manage the work such that prevailing wage work is performed during regular business hours.

SCADA & Control Systems – Inframark will provide a proposal to the Town for the SCADA integration, including asset monitoring, within the next month. Inframark has in-house SCADA companies that will save the Town costs in implementing the program and the asset monitoring.

SCADA will provide the Town with the following:

- Extend the useful life of assets
- Labor Savings
- Chemical/Energy Savings
- Lower Downtime/Risk

Inframark Provided Services for the Town of Carmel

Provide the labor and expertise to manage and operate the water supply and wastewater treatment system effectively, efficiently, and in compliance with laws and regulations, including:

- Providing 24/7 emergency response for water or wastewater-related issues.
- Providing required water and wastewater regulatory record keeping and reporting.
- Maintaining and implementing an emergency response plan; operations and maintenance plan; stormwater discharge; and Spill Prevention, Control, and Countermeasure (SPCC) plan for the sewer



districts.

- Receiving and responding to inquiries, requests for assistance, or complaints from customers or the general public, as required, and promptly notify appropriate Town officials, as needed.
- Providing notification to the owner of all situations that could cause system operational problems, dangers to the health, safety, and welfare of customers, neighboring individuals and landowners, or the environment in general.
- Receiving prior approval from the Town for any water plant shutdown, excluding emergencies.
- Securing the plants within the limits of existing security devices as the Town provides.
- Notifying the Town of any breach of security within one hour of determining such a breach has occurred. Assess the plant for breach of security impact(s) and notify the Town of any impact(s) as soon as such determination is made.
- Advising the Town of abnormal situations not within the contract operator's control that exceed hydraulic, organic, and inorganic loadings; exceeding treatment plant design criteria, permit parameters, or permit conditions; or violating federal, state, or local regulations.
- Reporting any event or permit violation required by regulatory agencies, such as untreated wastewater releases to surface waters, chlorine spills, etc. Provide immediate notification to the Town of a reportable event or permit violation.
- Assuming responsibility for any fines, operator-caused violations, and any fines or penalties due to fraud, negligence, or willful misconduct of the contract operator or the contract operator's employees.
- Provide required water and wastewater sampling and analysis.
- Place the orders for chemicals used in the operation of the water and wastewater facilities.
- Call to schedule sludge removal, transportation, and disposal for water and wastewater plants.
- Monitor the condition of the elevated water tanks and the operation of the tank control valves.

Provide maintenance of the water districts and wastewater districts, including the water system disinfection booster station including:

- Providing repairs to the water and wastewater treatment systems.
- Maintaining an adequate supply of spare parts.
- Providing facilities and grounds housekeeping.
- Assisting the Town with enforcement of existing equipment warranties and guarantees at the plant and maintaining all warranties on any new equipment purchased after the contract is signed and implemented.
- Monitoring wastewater lift stations on weekends and holidays.

Inframark Capabilities of Additional Services & Partnerships That Can Be Provided to the Town by Self-Performing or by Subcontracting



- SCADA & Control Systems/Asset Monitoring – Self Perform
- Full-Service Operations of all facilities – Self Perform
- Construction Management – Self Perform
 - » Maintenance and Capital Improvement Projects
 - » Design Phase Coordination
 - » Pre-Project Planning & Budgeting
 - » Project Management & Safety Compliance
 - » Project Closeout and Warranty Management
- Collection & Distribution System Assessment & Maintenance – Self Perform/Subcontract
- Water Holding Tank Inspections & Maintenance – Self Perform/Subcontract
- Concrete Assessment & Repair (Infiltration & Structural) - Subcontract

We sincerely thank you for your business and trust in us. We look forward to continuing our long-term partnership with the Town of Carmel.

In the meantime, if you have questions or require additional information, please do not hesitate to contact me at jerry.shupe@inframark.com or (434) 822-3635.

Sincerely,

INFRAMARK, LLC

Jerry Shupe,

Regional Vice President

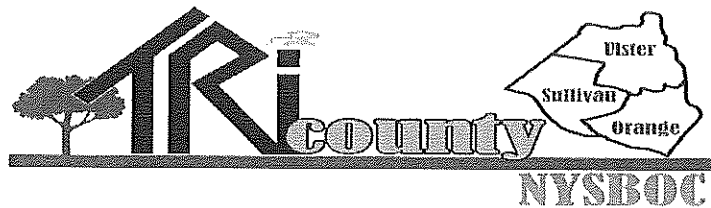

16th Annual Last Chance for Hours Conference

24 Hours In-Service Training Classes

Tuesday, November 15, 2022 thru Friday, November 18, 2022

Best Western Plus Kingston Hotel and Conference Center

503 Washington Avenue, Kingston, NY 12401

The cost is \$375.00 per person for 3.5 day event for NYSBOC Members
The cost is \$425.00 per person for 3.5 day event for Non-NYSBOC Members

Sign Up Early!

****Best West Plus Kingston Hotel and Conference Center, Kingston has rooms available ****
Use Group Name: NYSBOC

Call 845-338-0400 or 800-780-7234

www.bestwestern.com

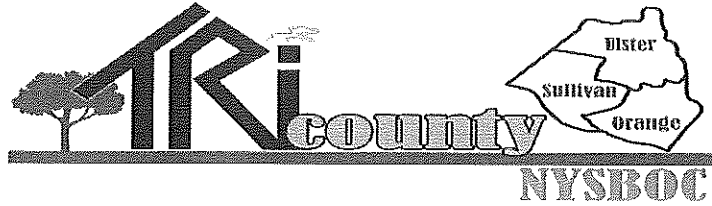

Pre-registration and payment is required

To register complete the information below and return it with a voucher, purchase order or check via mail as soon as possible.

**3.5 Day Conference – November 15th thru 18th, 2022
Offering 24 hours of continuing education**

Name: _____

Mailing Address: _____

City, St, Zip: _____

Municipality: _____

Business / Firm: _____

E-Mail: _____

(Primary source of contact is email - Please provide one)

Phone: _____ (Daytime phone #)

Fax: _____ (2nd Communication)

FD ID #: _____ NYS Training ID#: _____

Attending: _____ All 3.5 days

No refunds for cancellations received after October 24, 2022

Return form and voucher, purchase order or check to:
NYSBOC-Tri County Chapter
c/o BJ Gettel
PO Box 222
Kauneonga Lake, NY 12749
845-807-2273 (c) 845-583-4710 (fax)
Email: info@tricountynysboc.org

Classes are subject to change without notice!



Tri County Chapter of NYSBOC
PO Box 222
Kauneonga Lake, NY 12749

Serving Orange, Sullivan & Ulster Counties since 1947

Tri County 16th Annual Last Chance for Hours

Tuesday, November 15th

- 7:00 – 8:00 Registration, Continental Breakfast, Housekeeping & Opening Remarks
- 8:00 – 10:00 Accessibility
Course #: T02-07-2920
Instructor: Dominick Marinelli
- 10:00 – 2:00 NYSERDA Stretch Code Part 1 & 2
Course #: T02-07-2977 & T02-07-2976
Instructor: Chris Whitlet
- 12:00 -1:00 Lunch
- 2:00 – 5:00: Fire Resistant Wood Framing & Fire-Retardant Wood
Course #: T02-07-2835
Instructor: James Cogolski

Wednesday, November 16th

- 7:30 – 8:00 Registration, Continental Breakfast, Housekeeping & Opening Remarks
- 8:00 – 10:00 Changes to the 2020 Fire Code
Course #: T02-07-2855
Instructor: Chris Roth
- 10:00 – 12:00 NFPA 80 Fire Door
Course #: T02-07-3044
Instructor: Chris Roth
- 12:00 – 1:00 Buffet Lunch
- 1:00 – 3:00 Calculation for Egress
Course #: T02-07-3043
Instructor: Chris Roth



Tri County Chapter of NYSBOC
PO Box 222
Kauneonga Lake, NY 12749

Serving Orange, Sullivan & Ulster Counties since 1947

3:00 – 5:00 Mobile Food Trucks
Course#: T02-07- (49-7210)
Instructor: Chris Roth

Thursday, November 17th

7:30 – 8:00 Registration, Continental Breakfast, Housekeeping & Opening Remarks

8:00 – 3:00 CEO & BSI In-Service Inspection Program
Course #: T02-07-2943
Instructor: Adam McCarey

12:00 – 1:00 Buffet Lunch

Friday, November 18th

7:30 – 8:00 Registration, Continental Breakfast, Housekeeping & Opening Remarks

8:00 – 10:00 Fire resistant Construction IBC
Course #: T-02-07-3028
Instructor: Bruce Johnson

10:00 – 11:00 Overview of Building Emergency
Course #: T02-07-2946
Instructor: Bruce Johnson

11:00 – 12:00 UL Resources for Code Officials
Course#: T02-07-2858
Instructor: Bruce Johnson

*Thank you for attending the
16th Annual Last Chance for Hours Conference.
See you next year.*

TB-WS9-21-2022 Agenda Item#2

From: [Carnazza, Mike](#)
To: [Cazzari,Michael](#); [Pasquerello,Anne](#)
Subject: NYSERDA Training
Date: Monday, September 19, 2022 10:13:39 AM
Attachments: [20220919102724940.pdf](#)

Mike,

Both Ed Spadaro and I are registered for this FREE NYSERDA class, November 3, 2022 8:00 am-5:00 pm. in Newburgh.

If approved. we will drive up and back the same day.

The Town gets 1 action and 200 points in the NYSERDA Clean Energy Communities Program, which offers no-match grants for municipalities to put towards clean energy projects.

I'm away 9/28-10/5 so I would like to get on for the 2nd meeting in October.

Thank you,

Michael Carnazza
Director of Code Enforcement
Building Inspector
Town of Carmel
60 McAlpin Ave.
Mahopac, N.Y. 10541
(845) 628-1500 ext 170

Carnazza, Mike

From: Pasquerello, Anne
Sent: Wednesday, September 14, 2022 9:27 PM
To: Carnazza, Mike
Cc: Cazzari, Michael
Subject: FW: Code Trainings - First Step to NYSERDA Grant

Mike FYI

Anne Pasquerello

Chief of Staff
Carmel Town Hall
60 McAlpin Avenue
Mahopac, NY 10541
Office: 845-628-1500 ext. 137
Fax: 845-628-6836

This communication may be confidential and is intended for the sole use of the addressee(s). No use or reproduction of the information provided is permitted without the written consent of the Town of Carmel. If you are not the intended recipient, you should not copy, disclose or take any action in reliance on this communication. If you have received this communication in error, please notify the sender by reply e-mail and delete the message and any attached documents.

From: Eleanor Peck <epeck@hudsonvalleyrc.org>
Sent: Wednesday, September 14, 2022 10:22 AM
Cc: Carla Castillo <ccastillo@hudsonvalleyrc.org>
Subject: Code Trainings - First Step to NYSERDA Grant

CAUTION: This email originated from outside of the organization. Do not click links or open attachments unless you recognize the sender and know the content is safe.

Good Morning,

You are receiving this email because your municipality has not yet had a Code Enforcement Official take the NYSERDA Energy Code Enforcement Training.

We are hosting a training this fall in Newburgh: **Thursday, November 3 from 8am-5pm – 105 Ann Street, Newburgh:**
Here is a link to sign up: <https://events.eventzilla.net/e/energy-code-enforcement-training-hudson-valley-2138576235>

We encourage you to send a Code Enforcement Official to this training. It offers CEOs 8 hours of Dept. of State in-service credit. It also gives municipalities 1 action and 200 points in the NYSERDA Clean Energy Communities Program, which offers no-match grants for municipalities to put towards clean energy projects. Communities in the Mid-Hudson have cumulatively been awarded \$2,015,000 through this program already in 2021 and 2022 and we want to help your municipality get a grant in the program if you haven't yet.

Here is a testimonial from a Putnam County Building Inspector after taking a 2021 class, "Matt Evans with Newport Ventures presented the Commercial and Residential Energy Code in a practical application utilizing actual plan review and checklists to evaluate the plans provided. The training was provided in a classroom setting with a small group that provided the opportunity for interaction with the instructor and colleagues. The course provided an excellent opportunity to reinforce and build upon prior training opportunities provided by the Division of Codes." -- Michael Levine, Building Inspector, Town of Southeast

Please do not hesitate to reach out to me if you have any questions or concerns. HVRC staff is here to provide technical assistance for your municipality as it relates to the Climate Smart Communities Program and Clean Energy Communities Program.

Thank you for your time and consideration,



Eleanor Peck, MA (she/her) | Mid-Hudson Clean Energy Communities Manager & CEC Coordinator
HVRC | 105 Ann Street #2, Newburgh, NY 12550
Phone: 845-564-4075 | Virtual meeting: [Calendly link](#)
Check out HVRC's [Newsletter](#) & [Facebook page](#)!



Eleanor Peck, MA (she/her) | Mid-Hudson Clean Energy Communities Manager & CEC Coordinator
HVRC | 105 Ann Street #2, Newburgh, NY 12550
Phone: 845-564-4075 | Virtual meeting: [Calendly link](#)
Check out HVRC's [Newsletter](#) & [Facebook page](#)!



(<http://eventzilla.net/home>)

Energy Code Enforcement Training- Hudson Valley

Event

Registration

Confirmation

Congratulations! Your registration was successfully processed

Your ticket/confirmation receipt will be emailed to you within the next 5 to 10 minutes.

Your order details

ORDER ID

20229405046-7848656

[Add to my calendar](#)

Order Confirmation Receipt

Google (<http://www.google.com/calendar/event?action=TEMPLATE&text=Energy Code Enforcement Training- Hudson Valley&dates=20221103T120000Z/20221103T210000Z&location=105 Ann Street, Newburgh, NY, 12550, United States &details=For details visit..>
<http://ECETnewburgh.eventzilla.net/web/event?eventID=2138576235&trp=true&sprop=website:www.eventzilla.net&sprop=name:>)

Yahoo (<http://calendar.yahoo.com/?v=60&view=d&type=20&title=Energy Code Enforcement Training- Hudson Valley&st=20221103T120000Z&DUR=0900&desc=For details visit..>
[http://ECETnewburgh.eventzilla.net/web/event?eventID=2138576235&in_loc=105 Ann Street, Newburgh, NY, 12550, United States \)](http://ECETnewburgh.eventzilla.net/web/event?eventID=2138576235&in_loc=105 Ann Street, Newburgh, NY, 12550, United States))

Outlook ([addtocal.aspx?EventID=2138576235&start=20221103T120000Z&end=20221103T210000Z&venue=105 Ann Street, Newburgh, NY, 12550, United States \)](addtocal.aspx?EventID=2138576235&start=20221103T120000Z&end=20221103T210000Z&venue=105 Ann Street, Newburgh, NY, 12550, United States))
 iCal ([addtocal.aspx?EventID=2138576235&start=20221103T120000Z&end=20221103T210000Z&venue=105 Ann Street, Newburgh, NY, 12550, United States \)](addtocal.aspx?EventID=2138576235&start=20221103T120000Z&end=20221103T210000Z&venue=105 Ann Street, Newburgh, NY, 12550, United States)))

iCal ([addtocal.aspx?EventID=2138576235&start=20221103T120000Z&end=20221103T210000Z&venue=105 Ann Street, Newburgh, NY, 12550, United States \)](addtocal.aspx?EventID=2138576235&start=20221103T120000Z&end=20221103T210000Z&venue=105 Ann Street, Newburgh, NY, 12550, United States)))

Got a question?

Contact event organizer at sbowles@newportventures.net
 (<mailto:sbowles@newportventures.net>).

Hotel Booking



Organizing an event?

You can set up an event registration page and start accepting registration in minutes.
 Over 30,000 event organizers use Eventzilla for managing event registration and payments worldwide. No contacts, No setup fee, credit card required.

Create Event Now (<https://www.eventzilla.net/us/signup>)



This event is powered by Eventzilla. List your event today for free (<http://eventzilla.net/home>)

Contact Us (<http://eventzilla.net/contact>) Privacy Policy (<http://eventzilla.net/privacy>)

Terms of Service (<http://eventzilla.net/terms-conditions>) Report abuse

(<mailto:help@eventzilla.net?subject=Abuse>

Report&body=<https://www.eventzilla.net/web/event/energy-code-enforcement-training-hudson-valley-2138576235>)



TOWN OF CARMEL POLICE DEPARTMENT

60 MCALPIN AVENUE, MAHOPAC, NY 10541
TEL (845)628-1300 FAX (845)628-2597
POLICE@CI.CARMEL.NY.US

ANTHONY HOFFMANN
CHIEF OF POLICE

TB/WS9-21-2022 AGENDA ITEM #3

MEMORANDUM

TO: Carmel Town Board
FROM: Chief Anthony Hoffmann
SUBJECT: Education Stipends
DATE: September 21, 2022

According to Article XVII "Education and Training" of the current PBA contract, the following officers now qualify to receive education stipends:

PO Michelle Yeager # 62 – Bachelor's Degree from SUNY Plattsburgh	\$900.00 Stipend
Sgt. Sandy Crecco # 218 – Bachelor's Degree from SUNY Empire	\$900.00 Stipend
Chief Anthony Hoffmann - Bachelor's Degree from Iona College	\$900.00 Stipend

These officers meet the requirements of Article XVII, Section 2 of the current PBA contract as they have been members of CPD for over one year. Copies of the officer's diplomas and transcripts are on file with CPD's Administrative Division.

Submitted for your consideration and approval.

Chief Anthony Hoffmann

TB/WS9-21-2022 AGENDA ITEM #4



TOWN OF CARMEL RECREATION & PARKS DEPARTMENT
SYCAMORE PARK, 790 LONG POND ROAD
MAHOPAC, NEW YORK 10541

JAMES R. GILCHRIST, CPRP, DIRECTOR

TELEPHONE: (845) 628-7888 FAX: (845) 628-2820

EMAIL: carmelrecreation@ci.carmel.ny.us

WEB: <http://www.carmelny.org>

DATE: September 13, 2022

TO: Carmel Town Board
Carmel Town Hall

FROM: James R. Gilchrist, CPRP 
Director, Recreation and Parks

SUBJECT: Boiler Replacement Request for Recreation Building at Sycamore Park

The boiler located in the recreation building at Sycamore Park was replaced. I have attached three price quotes from the following vendors Bell Mechanical, LLC (\$12,477.00), Bottini Fuel (\$12,750.00) and Goodrow Fuel Oil Inc. (\$13,521.00). This has been submitted as an emergency purchase; a copy of the Emergency Justification Form is attached.

A Weil McLain Boiler was purchased and installed by Bell Mechanical, LLC.. I have attached the signed contract, and the Purchase Order in the amount of \$12,477.00, which includes equipment, installation and removal of the old unit.

This is a purchase that requires a Resolution. Please add this to the September 21, 2022 Town Board Work Session agenda and contact me with any questions.

/ns

Attachments

TOWN OF CARMEL

60 MCALPIN AVE
MAHOPAC, NY 10541

PO Number : 31808

Date : 09/01/2022

Page: 1 of 1

Purchase Order

Vendor : 0000000487
BELL MECHANICAL
PO BOX 242
MAHOPAC, NY 10541

Ship To:
TOWN OF CARMEL
RECREATION DEPT.
790 LONG POND ROAD
MAHOPAC, NY 10541
Phone # (845) 628-7888

Bill To:
TOWN OF CARMEL
RECREATION DEPT.
790 LONG POND ROAD
MAHOPAC, NY 10541

Description: WEIL MCLAIN BOILER FULL REPLACEMENT AT SYCAMORE PARK MAIN BUILDING

Qty.	Unit	Description	Unit Price	Amount
		RECREATION BUILDING WEIL MCLAIN WGO-4 BOILER, COILS, NEW CIRCULATORS AND TRIM KIT 100.7020.0045 (GENERAL FUND.REC.ADMIN.REC BLDG.SPECIAL REPAIRS)		12,477.00
		Total:		\$12,477.00

Ordered By: RECCLERK Req. Date: 09/01/2022 Req. No: 28078 Approved By/Date:

Authorized Official _____

Date _____

Handwritten signature:
Sent
VCF
9/9/22

EXHIBIT "B"

**Emergency Justification Form
Town of Carmel Procurement Policy**

Procurement Policy, Section VI: Emergency Procurement

Subdivision (4) of General Municipal Law §103 sets forth an exception to purchasing and bidding requirements for emergency situations

Department: Recreation
Vendor names: Goodrow, BELL, Bottini
Nature of emergency: Boiler @ main Bldg @ Sycamore
Estimated cost: \$12,500.00

There are three basic statutory criteria to be met in order to fall within the emergency purchase exception. State the basis for identifying an emergency purchase or service, check any that apply:

- The situation arose out of an accident or unforeseen occurrence or condition.
- Public buildings, public property, or the life, health, safety or property of the political sub-division's residents were affected.
- The situation required immediate action, which could not await competitive bidding.
- The emergency purchases or services exceeded \$10,000 and will be submitted to the Town Board for presentation at a Town Board Meeting to acknowledge said emergency. A Town Board Resolution should be passed acknowledging the same.
- Other (provide explanation):

Purchasing Agent's signature for approval:



Department Head's signature for approval:



Spano, Carmela

From: HVAC Proposals <communication@hvacbizpro.com>
Sent: Saturday, August 27, 2022 11:17 AM
To: Spano, Carmela
Subject: Bell Mechanical proposal for CARMELLA SPANO

CAUTION: This email originated from outside of the organization. Do not click links or open attachments unless you recognize the sender and know the content is safe.

[CLICK HERE TO VIEW PROPOSAL](#)

Here's the proposal you requested.

Thanks for considering us for your project, we promise to provide you with the highest level of customer service. Please review and let us know if you have any questions.



Thank You,

Bell Mechanical, LLC

200 Route, Mahopac, NY 10541

Tel: (845) 628-2580

www.bellhvac.com

2487

9/1/22
Einfused



200 Rt 6 Mahopac, NY 10541
845-600-8004
www.bellmech.com



Proposed by: John Irwin
(O) 845-628-2580 (C) 914-494-0564

john@bellhvac.com

Proposed for: CARMELLA SPANO

590 LONG POND RD
MAHOPAC, NY 10541
845-628-7888

cs@ci.carmel.ny.us

WEIL MCLAIN CUT AND SLIDE

Your investment

\$211/MO*

\$10,574

***WITH APPROVED CREDIT**

Net Investment

\$10,574

Financing Details:

Min. 2% payment 5.99% APR Payment based on 57.96 months

Quietside Weil Mclain wgo-4 boiler

Weil Mclain WGO-4 oil boiler with circulator and without tankless coil

Weil McLain cut and slide with new trim kit

WEIL MCLAIN FULL REPLACEMENT

Your investment

\$249/MO*

\$12,477

***WITH APPROVED CREDIT**

Net Investment

\$12,477

Financing Details:

Min. 2% payment 5.99% APR Payment based on 57.96 months

Quietside Weil Mclain wgo-4 boiler

Weil Mclain WGO-4 oil boiler with circulator and without tankless coil

Weil McLain full replacement with new circulators and trim kit

Included Services:

- POWER WIRING AND LOW VOLTAGE WIRING RECONNECTION INCLUDED
- REMOVE AND DISPOSE OF EXISTING UNIT AND WORK RELATED DEBRIS
- FURNISH AND INSTALL NEW WATER CONTROL TRIM KIT, EXPANSION TANK#30,FILL VALVE,BACK FLOW AND LOW WATER CUTOFF
- FURNISH AND INSTALL NECESSARY MATERIAL TO RECONNECT EXISTING OIL PIPING WITH NEW FILTER KIT AND ELECTRICAL CONNECTIONS AT NEW BOILER

- PERMIT FEES : \$300 FLAT FEE TO FILE AND WE WILL PASS PERMIT COSTS TO HOMEOWNER ONCE RECEIVED.
- START AND TEST COMPLETED INSTALLATION
- FURNISH AND INSTALL NEW FLUE PIPING FROM THE BOILER TO THE BASE OF THE EXISTING CHIMNEY
- FURNISH AND INSTALL 2 NEW TACO 007 CIRCULATOR

1

Choose Your Payment Option

Credit Card via Stripe

Financing

Check

2

Choose Your Equipment Option

Weil McLain Cut and slide

Weil McLain full replacement

3

Terms and Conditions

Terms and Conditions Payable as follows: 50% upon acceptance, Balance upon completion

All material and labor is guaranteed for 1 year. Additional warranties from manufacturer. All work to be completed in a workmanlike manner according to standard practices. Any alterations or deviation from above specifications involving extra cost will be executed only upon written orders, and will become an extra charge over and above the estimate. All major equipment and materials will be considered property of Bell Mechanical Inc. until project is paid in full. Unless otherwise noted, the equipment does not qualify for any energy rebates. All

agreements contingent upon strikes, accidents or delays beyond our control. Owner to carry fire, tornado and other necessary insurance. Our workers are fully covered by Workmen's Compensation Insurance. NOTE: This proposal may be withdrawn by us if not accepted within 30 days. The prices, specifications and conditions are satisfactory and are hereby accepted.

You are authorized to do the work as specified. Payment will be made as outlined above.

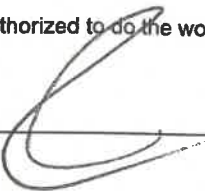
 _____ Date 9/1/22 Authorized Signature

_____ Date _____ Dealer Authorized Signature

Thank You

Bell Mechanical, LLC.

200 Route, Mahopac, NY 10541

Tel: (845) 628-2580

www.bellmech.com



BOILER REPLACEMENT - SPANO. - CARMEL REC- MCK • Date Created: 08-27-2022

4

Approve Your Proposal

Print your name

James Gilchrist

Draw your signature.



Clear

I accept the terms of this agreement.



Bottini Fuel

2785 W. Main St.
Wappingers Falls, NY 12590

P: 845.297.5580

F: 845.297.5465

E: info@bottinifuel.com

bottinifuel.com

INSTALLATION PROPOSAL

SALES EXECUTIVE: Vince Eagan

Town of Carmel
790 Long Pond Road
Mahopac NY 10541
Email: mt@ci.carmel.ny.us

Account # 902834

Date: 08/31/22

Phone: (845)628-7888

Re: 790 LONG POND RD SYCAMORE PARK

BOTTINI FUEL PROPOSES TO INSTALL THE FOLLOWING:

1. Remove existing boiler and cart away
2. Install new Peerless cast iron boiler complete with new flame retention burner
3. Install two new Grundfos circulator model# 15-58
4. Install new smoke pipe into existing chimney
5. Install 1 1/4 air scoop
6. Install two 1 1/4 black iron manifolds
7. Install taco switching relay model# SR502
8. Install boiler on durarock with 4-inch solid cement block
9. Pressure boiler
10. Install pressure reducing valve with back flow preventor
11. Install Honeywell manual reset aquastat

Note: reconnect to existing electrical circuit.

If floor isn't safe for any reasons, floor must be restructured by others.

If permits are required additional fees will be applied.

ALL LABOR AND MATERIALS FOR COMPLETE INSTALLATION



GOODROW FUEL OIL INC.



PROPOSAL # 1: _____

P.O. BOX 666
Mt. Kisco N.Y. 10549

Phone 845-628-3107
Fax 914-666-6743

WEIL MCLAIN BOILER, BURNER PROPOSAL

CUSTOMER: Town Carmel Recreation & Parks
ADDRESS: 790 Long Pond Raod
Mahopac NY 10541
EMAIL: JRG@CI.CARMEL.NY.US

DATE: AUGUST 18th 2022
PHONE: 845-628-7888
ACCOUNT: 72045407
ESTIMATOR: MARC E. SCUDER 914-666-4328 ext 130
914-525-1887

BOILER INCLUSIONS:	YES	NO
WEIL MCLAIN P-WGO-5 SERIES 4	X	
HYDRONIC BOILER WITH NEW 7" SMOKE PIPING	X	
2-TACO 0015 IFC HIGH SPED CIRCULATORS	X	
TACO AIR SCOOP 1X1/2"	X	
STEEL EZ HEADER / MANIFOLDS 1 1/4 X 3/4	X	
COMBO BOILER FAST FEED VALVE B911TMS 1/2"	X	
BACKFLOW/PREVENTOR LWCO	X	
1-#60 EXTROL EXP TANK	X	
BALL & CHECK VALVES 3/4	X	
ASST. COPPER PRO PRESS PIPING & FITTINGS	X	
CALEFFI AUTOMATIC AIR VENT IPS CHECK VALVE	X	
TACO MULTI ZONE RELAY	X	

ADDITIONAL EQUIPMENT & NOTES	YES	NO
BECKETT GO-5 OIL BURNER WITH FLEX OIL LINE	X	
NEW OIL FILTER COMPLETE & FIREMATIC VALVE	X	
7" SMOKE PIPING, DRAFT DAMPER, ELBOWS, TEE	X	
7" X 6" INCREASER INTO CHIMNEY FLUE	X	
REMOVAL & DISPONSAL OF OLD BOILER	X	
COMPLETE ALL WIRING	X	

MUST FILL OUT CAPITAL IMPROVEMENT FORM X
PERMITS MUST BE FILED BILLED SEPARATELY X
(2) YEARS FREE PLATINUM SERVICE PLAN X

THIS OFFER EXPIRES SEPTEMBER 30th 2022

(20) YEAR LIMITED WARRANTY HEAT EXCHANGER TRANSFERABLE X

TOTAL FEES: **\$13,521.00**

SIGNED: *Marc E. Scuder*

Please note: Goodrow Fuel is owned by Almeida Oil/Halstead Quinn
The above quote includes breaking all electrical and plumbing connections at the closest or most convenient locations, reusing all existing thermostats and switching relays. Any of this equipment found to be faulty will be replaced or repaired at additional cost at prevailing rates.

All material is warranted to be as specified. Any alteration or deviation from above specifications involving extra costs found during or after installations will be come an extra charge over and above this estimate. Halstead Quinn is not responsible for any pre-existing faulty piping water or steam leak(s), oil lines, poor draft, or electrical wiring etc. which may hinder the proper performance of the equipment being installed.

Halstead Quinn is not responsible for consequential damage caused by failure or delay in performing services herein contained. Halstead Quinn is not responsible for delays beyond its control. Homeowner to carry homeowners insurance (fire, etc.).

Customer agrees to participate in Halstead Quinn's automatic delivery program for 1 year from date of contract. If customer cancels automatic delivery prior to 1 year period, customer agrees to pay \$350.00 early termination fee or pro-rata portion thereof.

Finance charges of 1.5% per month will be assessed for any balances considered late by the terms of this contract. Customer shall pay any collection fees and attorneys necessary to secure late payments.

ACCEPTANCE OF PROPOSAL

The above prices, specifications and conditions are satisfactory and are hereby accepted as stated in:

Halstead Quinn is authorized to do the work as selected above. Payment will be made as follows: **50% DEPOSIT IS REQUIRED OF \$6,760.00**
FINAL PAYMENT DUE AFTER BILLED OUT

Customer signature

Date

Please print name here



Certificate of Capital Improvement

After this certificate is completed and signed by both the customer and the contractor performing the capital improvement, it must be kept by the contractor. Copies of this certificate must be furnished to all subcontractors on the job and retained as part of their records.

Read this form completely before making any entries.

This certificate may not be used to purchase building materials exempt from tax.

Name of contractor (print or type) Goodrow Fuel Oil Inc.			Name of customer (print or type) Town of Carmel Recreation & Parks		
Address (number and street) 33 Hubbells Drive			Address (number and street) 790 Long Pond Road		
City Marl Kisco	State NY	ZIP code 10549	City Mahopac	State NY	ZIP code 10541
Sales tax Certificate of Authority number (if any)					

To be completed by the customer

Describe capital improvement to be performed:

Replace existing boiler & burner complete. New Weil-McLain Gold W90-S series 4 boiler and Beckoff burner complete.

Project name Carmel Recreation & Parks			
Street address (where the work is to be performed) 790 Long Pond Road	City Mahopac	State NY	ZIP code 10541

I certify that:

- I am the (mark an X in one) owner tenant of the real property identified on this form; and
- the work described above will result in a capital improvement to the real property as outlined in the instructions of this form; and
- this contract (mark an X in one) includes does not include the sale of any items that will not become a permanent part of the real property (for example, a free-standing microwave or washing machine).

I understand that:

- I will be responsible for any sales tax, interest, and penalty due on the contractor's total charge for tangible personal property and for labor if it is determined that this work does not qualify as a capital improvement; and
- I will be required to pay the contractor the appropriate sales tax on tangible personal property (and any associated services) when the property installed by the contractor does not become a permanent part of the real property; and
- I will be subject to civil or criminal penalties (or both) under the Tax Law if I issue a false or fraudulent certificate.

Signature of customer <i>[Signature]</i>	Title	Date
---	-------	------

To be completed by the contractor

I, the contractor, certify that I have entered into a contract to perform the work described by the customer named above, and that I accept this form in good faith. (A copy of the written contract, if any, is attached.) I understand that my failure to collect tax as a result of accepting an improperly completed certificate will make me personally liable for the tax otherwise due, plus penalties and interest.

Signature of contractor or officer <i>[Signature]</i>	Title Service & Sales Mgr	Date 08/18/2022
--	------------------------------	--------------------

This certificate is not valid unless all entries are completed.



HIGH-EFFICIENCY
CAST IRON BOILER

WGO

APPLICATIONS INCLUDE:

- Residential
- Light Commercial
- Multiple Boilers
- Indirect-fired Water Heating
- Radiant Heating

*Model Dependent

*ENERGY STAR® requires a minimum of 87% AFUE, which is only achieved by reducing the burner rate and installing the specified optional vent damper kit. See Ratings chart on next page.



CAST TO LAST



**HEAT EXCHANGER
MADE IN THE USA**

DIMENSIONS

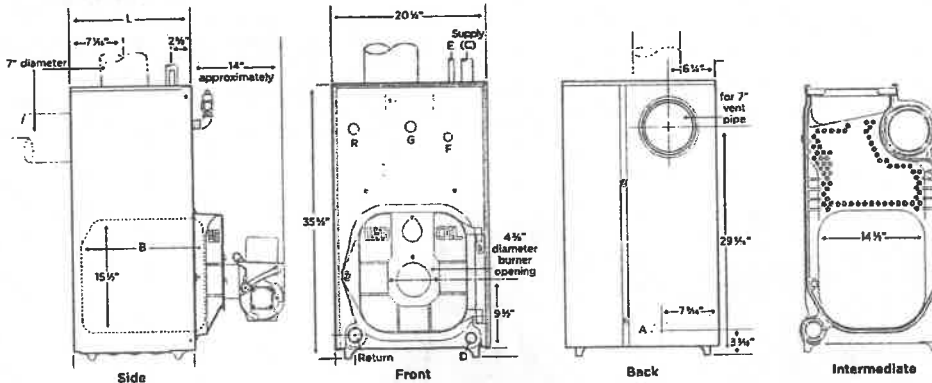

Tapping Location	Size (in.)	Control Tappings
A	1½	Alternative return — semi packaged & knocked down units only
G	¼	Pressure/temperature gauge
D	¾	Drain valve
F	¾	High limit/circulator control
E	½	Piping to expansion tank or automatic air vent
R	¾	Relief valve

Boiler Size	Supply C (in.)		Return (in.)	Dimensions (in.)	
	Packaged with Circulator	Semi-Packaged & Knocked-Down		B	L
WGO-2	1¼ (circulator flange)	1½	1½	10½	13 ¾
WGO-3	1¼ (circulator flange)	1½	1½	13½	16½
WGO-4	1¼ (circulator flange)	1½	1½	13¾	16¾
WGO-5	1¼ (circulator flange)	1½	1½	16¾	20
WGO-6	1¼ (circulator flange)	1½	1½	20	23¾
WGO-7	not applicable	1½	1½	23¾	26¼
WGO-8	not applicable	1½	1½	26¼	29¾
WGO-9	not applicable	1½	1½	29¾	32½

RATINGS

ENERGY STAR*	Model*	Burner Input Rating		AHRI Certified Ratings			Draft Loss Through Boiler (in. w/c)	Minimum Chimney Size			Approx. Shipping Weight (Lbs.)												
		GPH ¹	MBH ²	Heating Capacity (MBH) ²	Net Ratings (MBH) ^{2a}	AFUE		Rectangular (in.)	Round (in.)	Height (Ft.)													
•	WGO-2	0.70	98	86	75	86.4	.010	8x8	15	760	540												
	WGO-2RD	0.70	98	86	75	87.0	.010				540												
•	WGO-3R	0.80	112	98	85	86.2	.020				8x12	20	1,030	595									
	WGO-3RD	0.80	112	98	85	87.0	.010							595									
•	WGO-4R	1.00	140	122	106	86.2	.010							8x12	20	1,030	645						
	WGO-4RD	1.00	140	123	107	87.0	.010										645						
•	WGO-4D	1.20	168	146	127	86.0	.010										8x12	20	1,030	645			
	WGO-5R	1.20	168	147	128	86.1	.015													760			
•	WGO-5RD	1.20	168	148	129	87.0	.015													8x12	20	1,030	760
	WGO-5D	1.45	203	176	153	86.0	.015																760
•	WGO-6R	1.40	196	171	149	86.1	.015	8x12	20	1,030													860
	WGO-6RD	1.40	196	173	150	87.0	.015																860
•	WGO-6D	1.75	245	213	185	86.0	.015				8x12	20	1,030										860
	WGO-7R	1.60	224	196	170	86.0	.015																930
•	WGO-7RD	1.60	224	197	171	87.0	.015							8x12	20	1,030							930
	WGO-7D	2.00	280	244	212	86.0	.015																930
•	WGO-8	2.30	322	266	231	-	.025										8x12	20	1,030				1,030
	WGO-9	2.55	357	295	257	-	.030																1,135

Boiler order options include

Packaged boiler: Assembled block with jacket, collector hood and controls installed (order burner separately); sizes 2-6.

Semi-packaged boiler: Assembled block with jacket and collector hood installed (order burner and trim separately); sizes 2-6.

Knocked-down boiler: Assembled block, all other components are cartoned and shipped separately; all sizes.

STANDARD EQUIPMENT:

BOILER

- Factory tested and assembled cast iron section assembly (jacket and collector hood are not assembled on 7, 8 and 9 section blocks)
- Insulated steel jacket
- Aluminized steel flue collector hood with flue cap on top outlet (convertible to rear outlet)
- Swing-away burner mounting door
- Refractory blanket and target wall in combustion area
- Circulator (when ordered)
 - Sizes 2-4: Taco 007e
 - Sizes 5-6: Taco 007
- High limit control with circulator relay, LWCO function, and integrated service switch
- Two vent pipe brackets
- Pressure/temperature gauge
- 30 PSIG ASME relief valve (boiler sections tested for 50 PSIG working pressure)
- Drain valve
- Barometric damper
- Built-in air separator

OPTIONAL EQUIPMENT:

- High-efficiency flame-retention oil burner (Beckett AFG, Carlin EZ or Riello). Specify 2-stage fuel unit (optional, Beckett) if required
- Vent damper kit
- Outdoor reset kit - temperature sensor (wired version part #383-500-126, wireless version part #386-701-047)
- Weil-McLain five- and ten-year homeowner protection plan
- Weil-McLain indirect-fired water heaters

LIMITED TRANSFERABLE WARRANTY:

- Residential: 20 Years Heat Exchanger; 2 Years Parts
- Commercial: 10 Years Heat Exchanger; 1 Year Parts

*Boiler model suffixes:

R = Reduced input version—a burner nozzle change may be required, refer to the burner instructions or boiler's rating label for correct selection. No separate/additional damper kit required.

D = High Input version—installation of the separate High Input Vent Damper kit (part # 381800515) is required, also a burner nozzle change may be required, refer to the burner instructions or boiler's rating label for correct selection.

RD = ENERGY STAR 87% AFUE compliant only when installed with the separate ES Vent Damper kit (part numbers 381800501 through 381800506) and at the reduced burner rate.

*No. 2 fuel oil—Commercial Standard Specification CS75-56, Heating value of oil-140,000 BTU/Gal.

*Based on standard test procedures prescribed by the United States Department of Energy.

²MBH refers to thousands of BTU per hour.

*Net AHRI ratings are based on net installed radiation adequate for the requirements of the building, including a piping and pickup allowance of 1.15-sufficient for normal conditions. Provide additional allowance only for unusual piping and pickup loads.



Weil-McLain® Cast Iron Oil Boiler Models WGO, WTGO, and UO

Limited Warranty for Residential Use

Please register your purchase of this Weil-McLain Product at www.weil-mclain.com.
Retain proof of purchase and installation date.

A. What Does This Limited Warranty Cover?

This Limited Warranty for Residential Use covers any defects in material and workmanship in your Weil-McLain Cast Iron Oil Boiler Model WGO, WTGO, or UO (the "Product").

B. How Long Does The Coverage Last?

There are two separate coverage periods under this Limited Warranty: (1) the Heat Exchanger Limited Warranty Period, and (2) the Parts Limited Warranty Period. The Heat Exchanger Limited Warranty Period runs for twenty years from the date your Product was installed. The Parts Limited Warranty Period runs for two years from the date your Product was installed and applies to all parts of your Product except the heat exchanger.

Item	Coverage
Heat Exchanger	20 years
All Other Parts	2 years

C. Who Can Make Claims Under This Limited Warranty?

This Limited Warranty is available to you if you are the original retail purchaser or a subsequent owner and the Product has only been used for personal, family, or household purposes. Weil-McLain defines Products "used for personal, family, or household purposes" as any Products used in (1) any single-family dwelling or (2) a two-family owner-occupied solely residential building where the Product services the owner's residence. Weil-McLain defines Products used in any other manner to be Products "used for business purposes." This Limited Warranty does not provide coverage to you if you use the Product at any time for business purposes. A Product used at any time for business purposes is covered by the Limited Warranty for Commercial Use for the Weil-McLain Cast Iron Oil Boiler Models WGO, WTGO, and UO.

D. What Will Weil-McLain Do To Correct Problems?

If Weil-McLain determines during the first five years of the Heat Exchanger Limited Warranty Period that the heat exchanger is defective in material or workmanship, then Weil-McLain will provide a replacement boiler (exclusive of any burner used in connection with the boiler). If Weil-McLain determines during the sixth through twentieth year of the Heat Exchanger Limited Warranty Period that the heat exchanger is defective in material or workmanship, then Weil-McLain will provide a replacement heat exchanger. If Weil-McLain determines during the Parts Limited Warranty Period that any part other than the heat exchanger is defective in material or workmanship, then Weil-McLain will provide a replacement part.

Weil-McLain will provide replacement boilers, heat exchangers, and other parts free of charge. Weil-McLain will furnish replacement boilers and heat exchangers from the closest comparable boiler model available from Weil-McLain at the time of the replacement.

If Weil-McLain provides a replacement boiler for a defective heat exchanger, then the heat exchanger and all other parts in the replacement boiler will be covered under this Limited Warranty for the time remaining, if any, in the original Limited Warranty Period applicable to the like item in the original boiler. If Weil-McLain provides a replacement heat exchanger, then that replacement heat exchanger will be covered under this Limited Warranty for the time remaining in the original Heat Exchanger Limited Warranty Period. If Weil-McLain provides a replacement for any part other than the heat exchanger, then that replacement part will be covered under this Limited Warranty for the time remaining in the original Parts Limited Warranty Period.

E. What Will Weil-McLain Not Do To Correct Problems?

Weil-McLain will not pay for the labor to remove any boiler, heat exchanger, or other part that is the subject of your warranty claim or to install replacements provided under this Limited Warranty. Additionally, Weil-McLain will not pay for the cost of any tools, repair materials, or travel necessary to perform the removal or installation.

Weil-McLain® Cast Iron Oil Boiler

Models WGO, WTGO, and UO

Limited Warranty for Residential Use

F. What Is Not Covered Under This Limited Warranty?

This Limited Warranty does not cover any Product that has been moved from its original installation site; any components that are not supplied by Weil-McLain; and any burner supplied by Weil-McLain. (Burners supplied by Weil-McLain are covered by a separate manufacturer's warranty.) Additionally, this Limited Warranty does not cover claims you make if the failure, malfunction, or unsatisfactory performance of, or damage to, your Product resulted from or is attributable to:

- (1) Inaccurate or incomplete information or data supplied or approved by any party other than Weil-McLain;
- (2) The failure to properly size the Product for its use;
- (3) Installation not done in accordance with manufacturer's instructions;
- (4) Services provided by and workmanship of the installer of the Product;
- (5) Components that are not supplied by Weil-McLain;
- (6) Improper or negligent operation, adjustment, control settings, repair, care, or maintenance of the Products, or the failure to adjust, set the controls of, repair, care for, or maintain the Products;
- (7) Operation with combustion air contaminated by chemical vapors, with improper fuel additives, or with water conditions that have caused deterioration or unusual deposits in the heat exchanger;
- (8) Freezing, accident, fire, flood, or other acts of God; abuse or misuse; unauthorized alteration; or power surges or failures; and
- (9) Normal wear and tear.

WEIL-McLAIN'S MAXIMUM LIABILITY SHALL NOT EXCEED THE ACTUAL PURCHASE PRICE PAID BY YOU FOR YOUR PRODUCT. IN NO EVENT SHALL WEIL-McLAIN BE RESPONSIBLE FOR INDIRECT, INCIDENTAL, CONSEQUENTIAL (INCLUDING WITHOUT LIMITATION DAMAGE TO OR LOSS OF OTHER PROPERTY), OR PUNITIVE DAMAGES, WHETHER SUCH CLAIM OR ACTION IS BASED ON CONTRACT, WARRANTY, NEGLIGENCE, STRICT LIABILITY, OR ANY OTHER LEGAL THEORY. Some states do not allow the exclusion or limitation of incidental or consequential damages, so the above limitation or exclusion may not apply to you.

ALL IMPLIED WARRANTIES ARE LIMITED IN THEIR DURATION TO THE APPLICABLE WARRANTY PERIOD STATED ABOVE. ALL IMPLIED WARRANTIES, INCLUDING MERCHANTABILITY AND FITNESS FOR A PARTICULAR PURPOSE, ARE DISCLAIMED IN THEIR ENTIRETY AFTER EXPIRATION OF THEIR APPLICABLE WARRANTY PERIOD SET FORTH ABOVE. Some states do not allow limitations on how long an implied warranty lasts, so the above limitation may not apply to you.

G. How Do You Make A Warranty Claim?

If you believe you have a claim under this Limited Warranty, please contact a heating or plumbing contractor of your choice. Your contractor will perform a diagnosis and advise you as to whether you may have a claim covered by this Limited Warranty. If your contractor advises you that you may have a claim covered by this Limited Warranty, then the contractor will file the claim with Weil-McLain on your behalf. You must make all parts that are subject to a warranty claim available to your contractor for return to Weil-McLain. If you have questions about this process or the status of your claim, you may contact the Weil-McLain Warranty Center, 523 S New Street, Eden, NC, 27288, or call 1-800-654-2109, Option 3, or email wm.w@weil-mclain.com. In addition to the information provided here, you can find complete warranty details and procedures at www.weil-mclain.com.

H. How Can You Register Your Purchase?

Please register your purchase at www.weil-mclain.com. Registration is not required to activate your warranty, but you should retain proof of purchase and installation date.

I. How Does State Law Relate To This Limited Warranty?

This Limited Warranty gives you specific legal rights, and you may also have other rights that vary from state to state.

* * *

If you have any questions about your coverage under this Limited Warranty, please contact Weil-McLain using the contact information provided above. To learn how to properly care for and maintain your Product, please review the printed information provided with your Product. You can also obtain this information at www.weil-mclain.com.

Spano,Carmela

From: Gilchrist, Jim
Sent: Friday, August 19, 2022 3:07 PM
To: Spano,Carmela
Subject: FW: boiler proposal
Attachments: TOWN OF CARMEL REC AND PARKS PROPOSAL.pdf

Please get 2 other quotes. Maybe Bell and the company that supplies our heating oil.

From: Marc Scuder [<mailto:marc@hqpetroleum.com>]
Sent: Friday, August 19, 2022 2:44 PM
To: Gilchrist, Jim
Subject: Re: boiler proposal

CAUTION: This email originated from outside of the organization. Do not click links or open attachments unless you recognize the sender and know the content is safe.

Sorry I forgot to attach!

On Fri, Aug 19, 2022 at 2:43 PM Marc Scuder <marc@hqpetroleum.com> wrote:

Hello and good afternoon Mr Gilchrist

As discussed, from my visit this past Wednesday. Here is my proposal for your boiler replacement. Please note that the proposal covers all our work and material. It does not cover permits, which will be billed separately. Of course if we move forward. If you have any questions or concerns please do not hesitate to contact me. If all is in order, and you wish to move forward. Please sign both forms and email back to me. Once received I will start the process and file the permit.

Best regards
Marc E. Scuder
914-666-4328 EXT 130
914-525-1887